

# HIGH CURRENT POWER INDUCTORS

## CEP 104 SERIES

### FEATURES:

- Compact size using flat wire, and SMD type
- Low radiation noise by magnetically shielded construction
- High current
- Low resistance

### COMMON APPLICATIONS:

- High efficiency DC/DC converters
- Single and polyphase buck converters
- Filter for audio applications
- Optimized for high current boost applications

### ELECTRICAL CHARACTERISTICS:

Part No.	Inductance @ 100KHz ( $\mu\text{H}$ ) $\pm 20\%$	DCR ( $\text{m}\Omega$ ) Max	DC saturation current			Temperature rise 40°C current (A) Max
			L0 Drop 10% Max	L0 Drop 20% Max	L0 Drop 30% Max	
CEP104-0R8	0.8	4.0	24.9	25.2	25.6	16.3
CEP104-1R0	1.0	4.0	16.5	17.0	17.5	16.3
CEP104-1R2	1.2	6.0	20.5	21.0	21.3	15.0
CEP104-1R3	1.3	4.0	12.9	16.8	17.2	16.3
CEP104-1R5	1.5	4.0	13.5	14.0	14.5	16.3
CEP104-1R8	1.8	6.0	13.3	13.8	14.3	15.0
CEP104-2R0	2.0	9.0	15.3	15.8	16.2	11.5
CEP104-2R2	2.2	4.0	8.9	9.6	10.0	16.3
CEP104-2R5	2.5	7.5	11.4	11.8	12.1	12.0
CEP104-3R2	3.2	6.0	7.3	8.0	8.5	15.0
CEP104-4R0	4.0	9.0	8.3	8.5	8.8	11.5
CEP104-4R3	4.3	7.5	6.4	6.8	7.0	12.0
CEP104-5R7	5.7	9.0	5.4	5.8	6.0	11.5

### TECHNICAL INFORMATION & PHYSICAL CHARACTERISTICS:

#### Dimensions(mm)

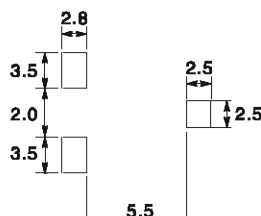
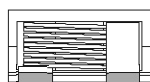
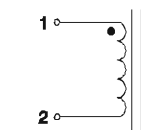
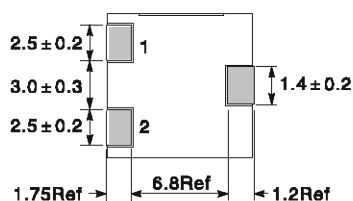
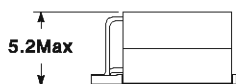
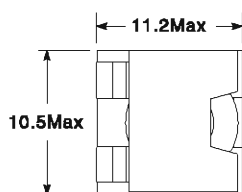

LAND PATTERNS

- Test Frequency : 100KHz / 0.25V
- Testing Instrument : L:HP4284A, CH11025, CH3302, CH1320, CH1320S LCR METER/Rdc:CH16502, Agilent33420A MICRO OHMMETER.
- The part temperature (ambient + temp rise) should not exceed 125°C under worst case operating conditions. Circuit design, component, PCB trace size and thickness, airflow and other cooling provisions all affect the part temperature. Part temperature should be verified in the end application.
- Operating Temperature & Storage Temperature: -40°C - +105°C.
- All specifications subject to change without notice.

**ELECTRICAL CHARACTERISTIC CURVE:**

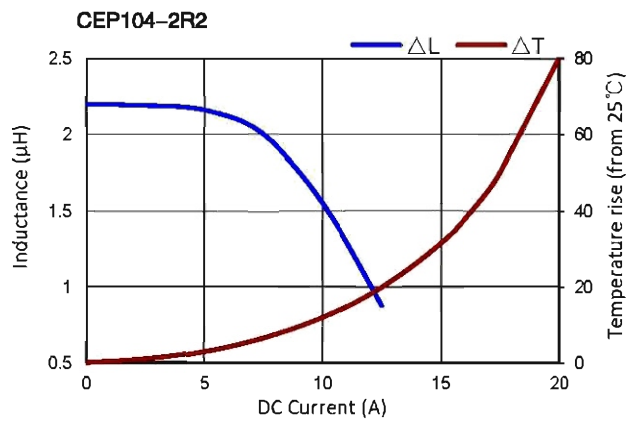
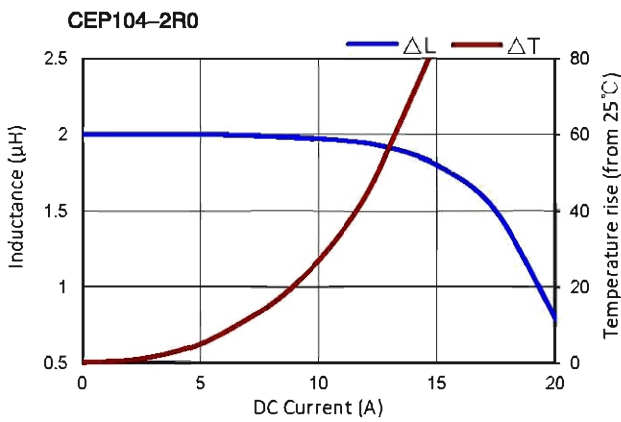
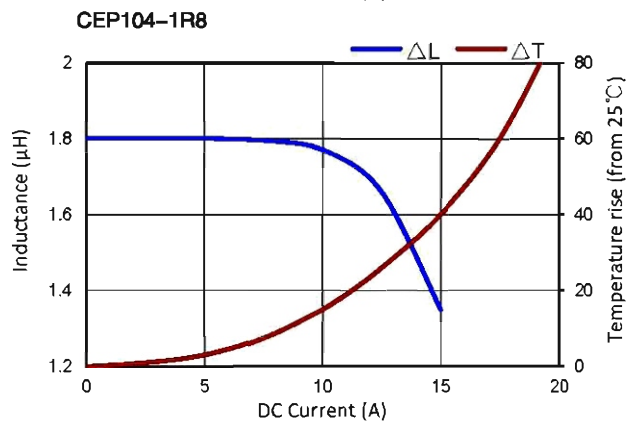
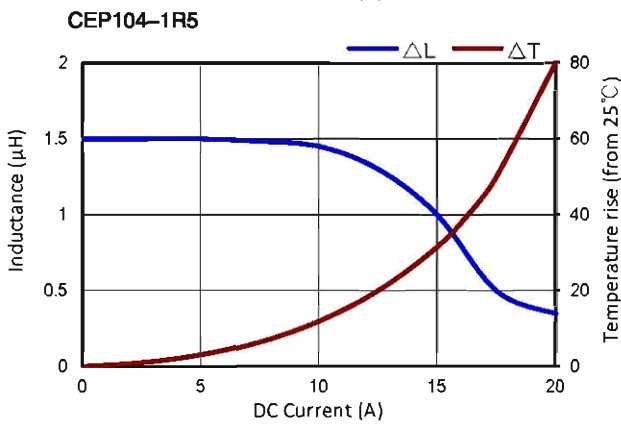
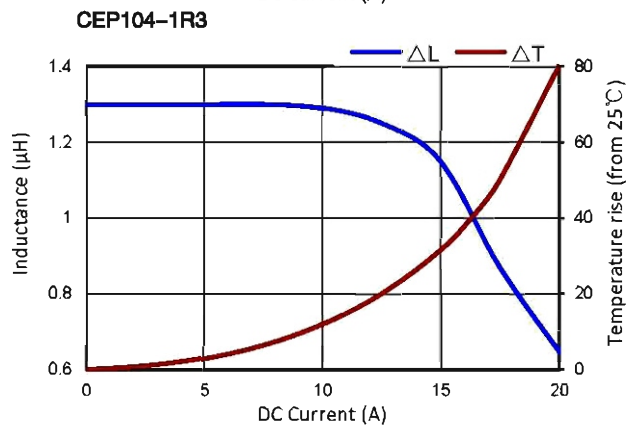
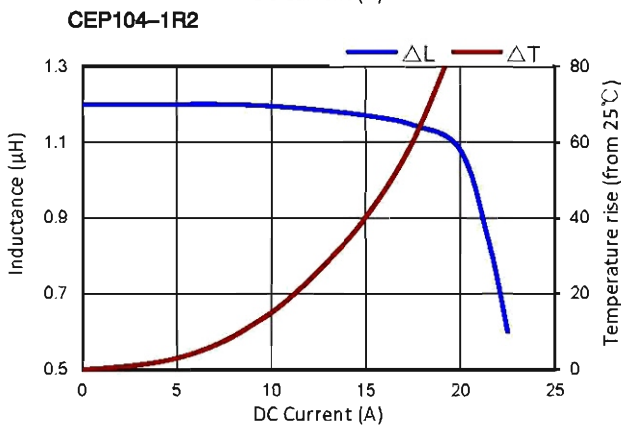
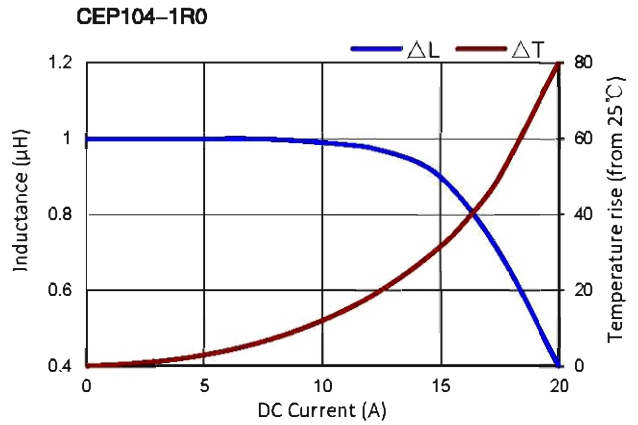
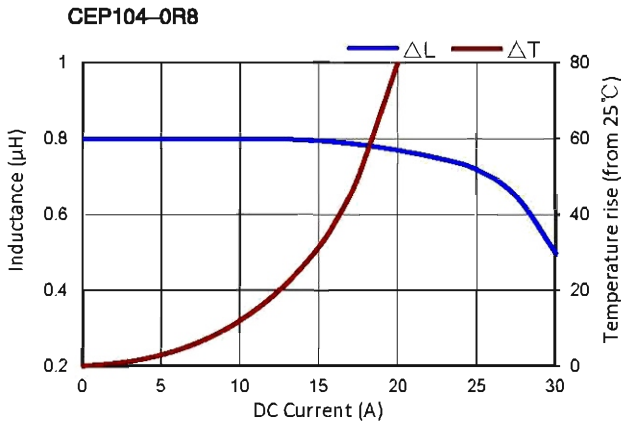

**ELECTRICAL CHARACTERISTIC CURVE:**

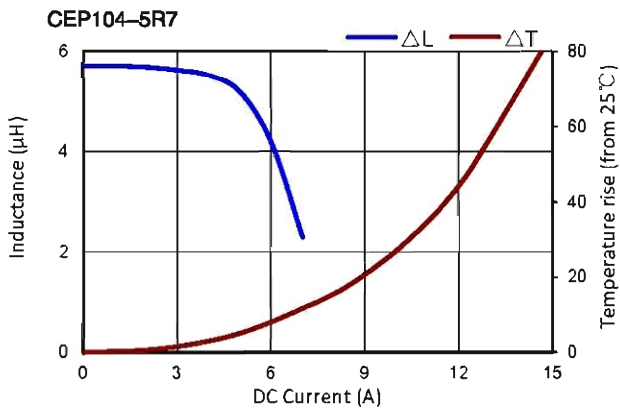
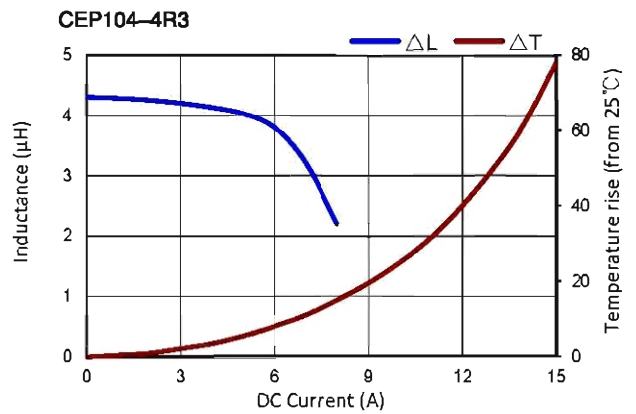
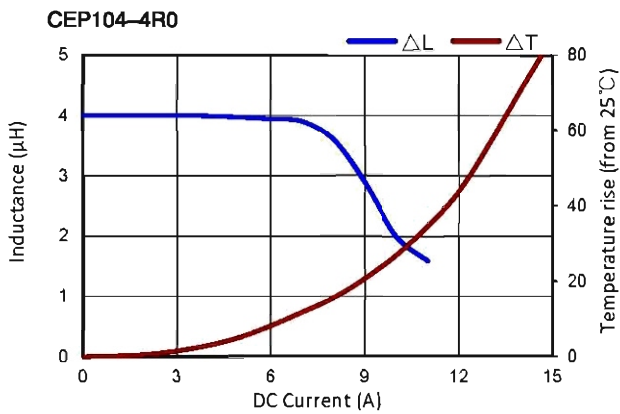
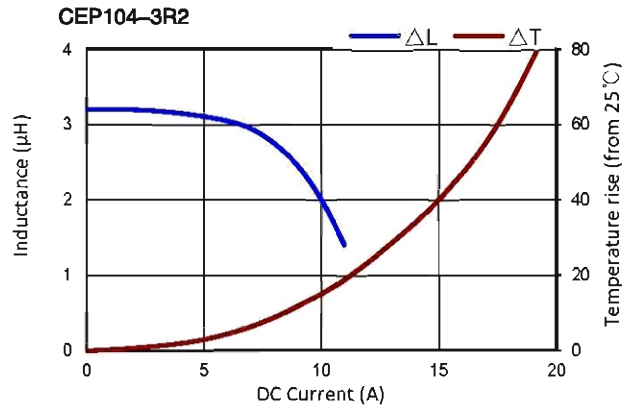
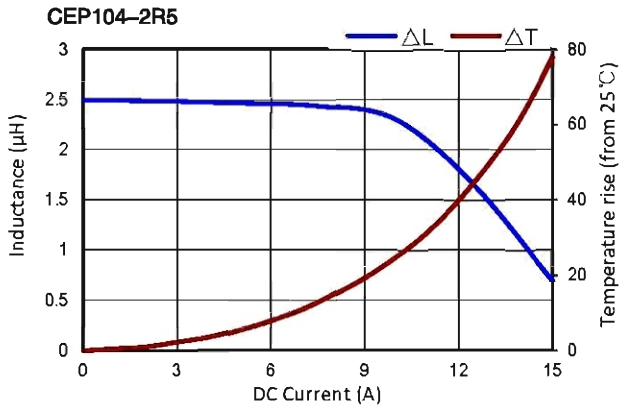

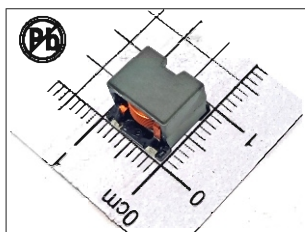

# HIGH CURRENT POWER INDUCTORS

## CEP 105 SERIES

### FEATURES:

- Compact size using flat wire, and SMD type
- Low radiation noise by magnetically shielded construction
- High current
- Low resistance

### COMMON APPLICATIONS:

- High efficiency DC/DC converters
- Single and polyphase buck converters
- Filter for audio applications
- Optimized for high current boost applications

### ELECTRICAL CHARACTERISTICS:

Part No.	Inductance @ 100KHz ( $\mu$ H) $\pm$ 20%	DCR (m $\Omega$ ) Max	DC saturation current			Temperature rise 40 $^{\circ}$ C current (A) Max
			L0 Drop 10% Max	L0 Drop 20% Max	L0 Drop 30% Max	
CEP105-5R6	5.6	10.5	4.0	7.8	10.5	8.5
CEP105-6R8	6.8	12.0	3.5	6.8	9.8	7.8
CEP105-9R0	9.0	16.0	3.2	5.7	9.1	6.6
CEP105-100	10.0	18.8	3.0	5.5	9.0	6.0
CEP105-120	12.0	21.0	2.4	5.0	7.2	5.2
CEP105-150	15.0	26.5	2.0	4.2	6.5	4.6
CEP105-220	22.0	40.0	2.0	3.0	5.2	4.0

### TECHNICAL INFORMATION & PHYSICAL CHARACTERISTICS:

#### Dimensions(mm)

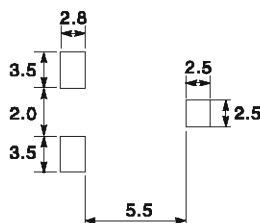
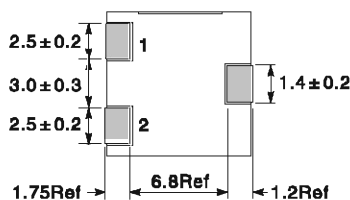
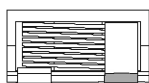
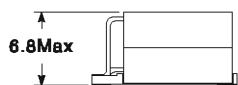
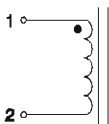
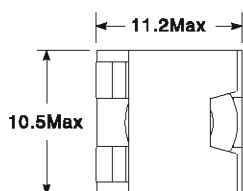

LAND PATTERNS

- Test Frequency : 100KHz / 0.25V
- Testing Instrument : L:HP4284A, CH11025, CH3302, CH1320, CH1320S LCR METER/Rdc:CH16502, Agilent33420A MICRO OHMMETER.
- The part temperature (ambient + temp rise) should not exceed 125 $^{\circ}$ C under worst case operating conditions. Circuit design, component, PCB trace size and thickness, airflow and other cooling provisions all affect the part temperature. Part temperature should be verified in the end application.
- Operating Temperature & Storage Temperature: -40 $^{\circ}$ C - +105 $^{\circ}$ C.
- All specifications subject to change without notice.

**ELECTRICAL CHARACTERISTIC CURVE:**

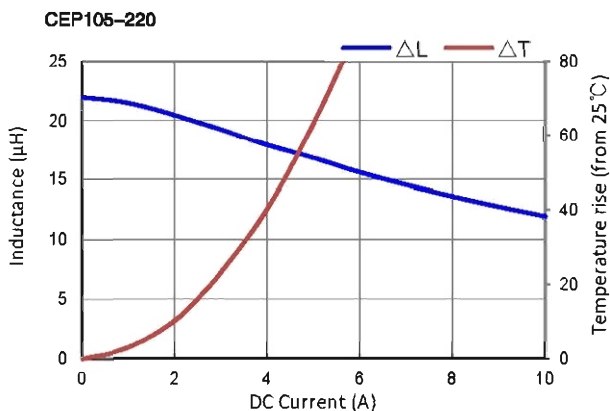
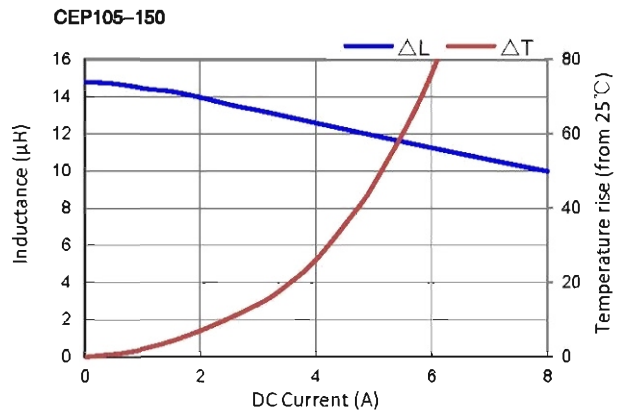
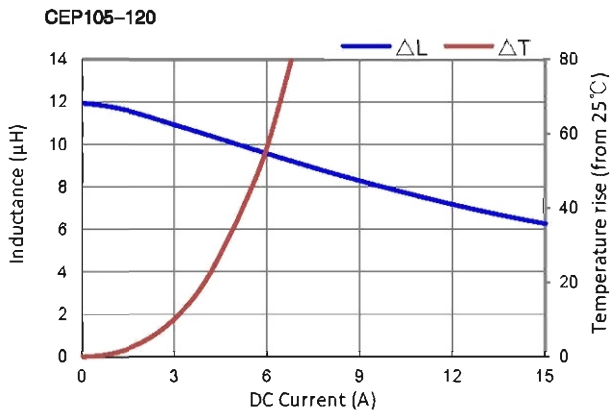
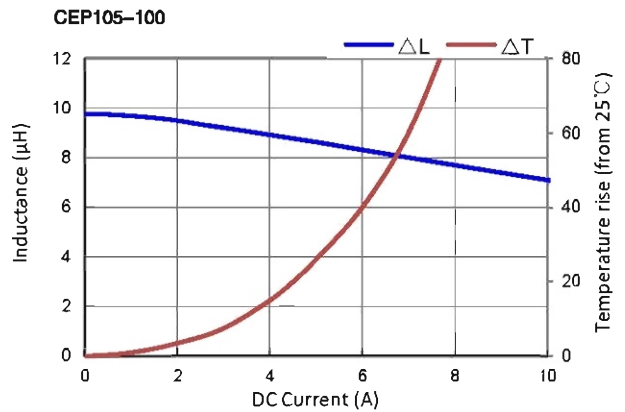
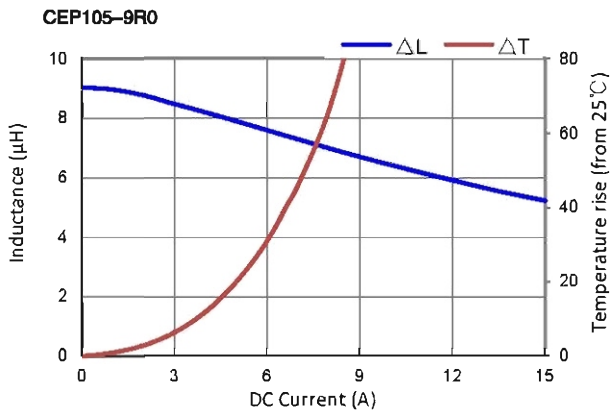
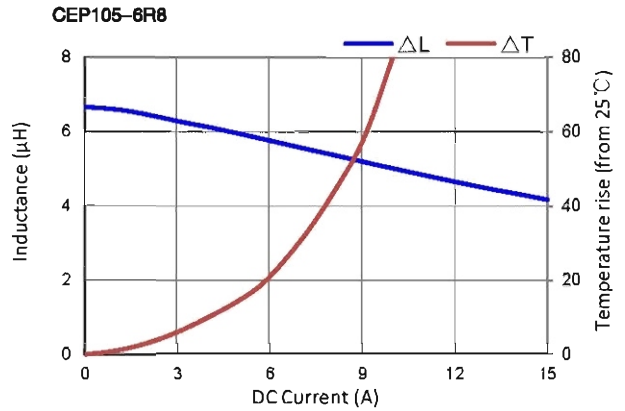
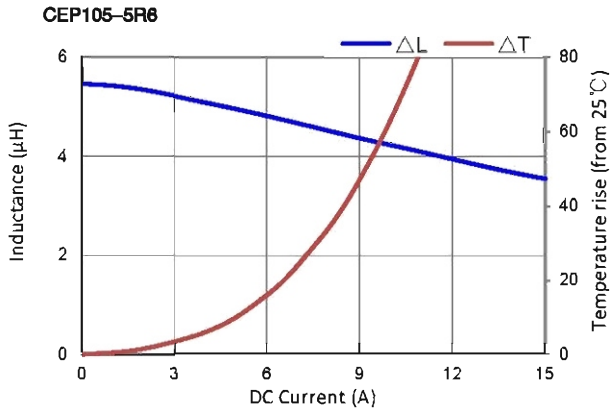

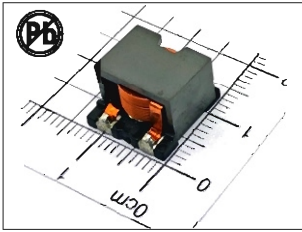

# HIGH CURRENT POWER INDUCTORS

## CEP 136 SERIES

### FEATURES:

- Compact size using flat wire, and SMD type
- Low radiation noise by magnetically shielded construction
- High current
- Low resistance

### COMMON APPLICATIONS:

- High efficiency DC/DC converters
- Single and polyphase buck converters
- Filter for audio applications
- Optimized for high current boost applications

### ELECTRICAL CHARACTERISTICS:

Part No.	Inductance @ 100KHz (uH) ± 20%	DCR (mΩ) Max	DC saturation current			Temperature rise 40°C current (A) Max
			L0 Drop 10% Max	L0 Drop 20% Max	L0 Drop 30% Max	
CEP136-1R0	1.0	2.6	32	33	33.5	13
CEP136-2R2	2.2	2.6	15	17	18	13
CEP136-2R7	2.7	2.6	12	13	14	13
CEP136-3R3	3.3	6.0	11.5	12.5	13.5	9.4
CEP136-4R7	4.7	6.0	9.5	11	12	9.4
CEP136-6R8	6.8	6.0	8.0	9	9.5	9.4
CEP136-8R2	8.2	10.8	7.5	8.5	9	7.6
CEP136-100	10	10.8	6.2	7	7.5	7.6

### TECHNICAL INFORMATION & PHYSICAL CHARACTERISTICS:

#### Dimensions(mm)

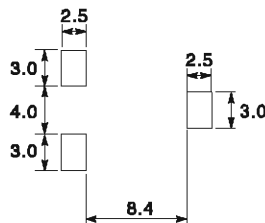
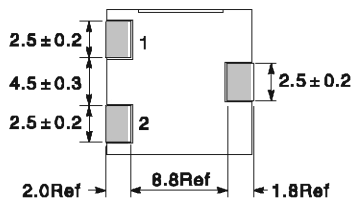
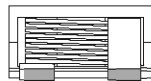
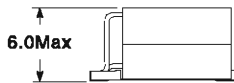
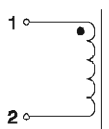
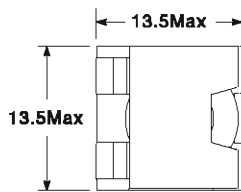

LAND PATTERNS

- Test Frequency : 100KHz / 0.25V
- Testing Instrument : L:HP4284A, CH11025, CH3302, CH1320, CH1320S LCR METER/Rdc:CH16502, Agilent33420A MICRO OHMMETER.
- The part temperature (ambient + temp rise) should not exceed 125°C under worst case operating conditions. Circuit design, component, PCB trace size and thickness, airflow and other cooling provisions all affect the part temperature. Part temperature should be verified in the end application.
- Operating Temperature & Storage Temperature: -40°C - +105°C.
- All specifications subject to change without notice.

**ELECTRICAL CHARACTERISTIC CURVE:**

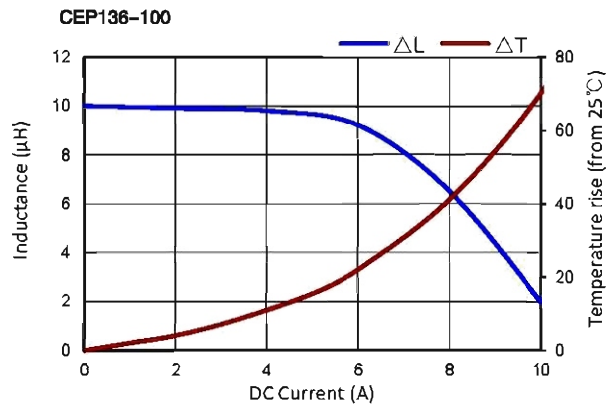
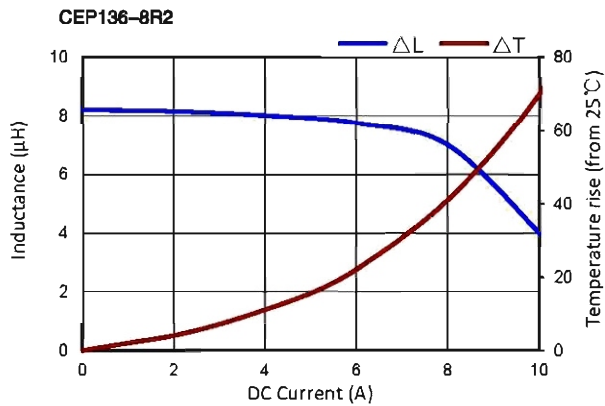
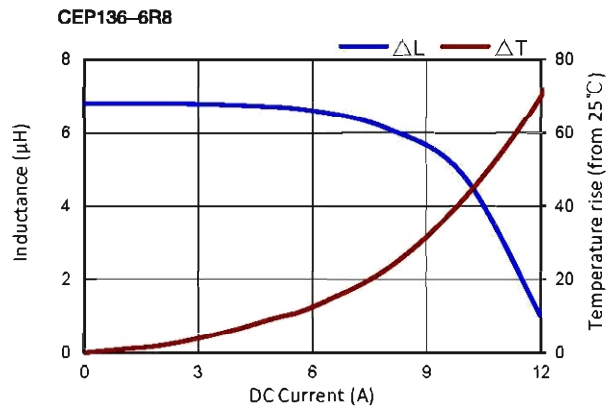
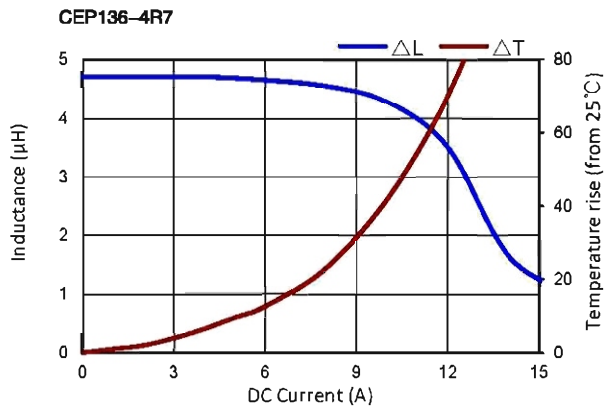
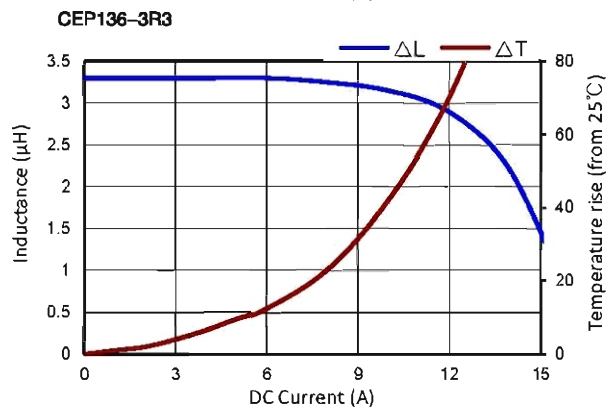
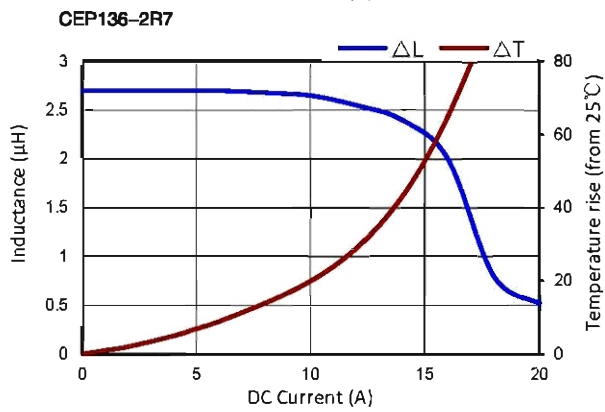
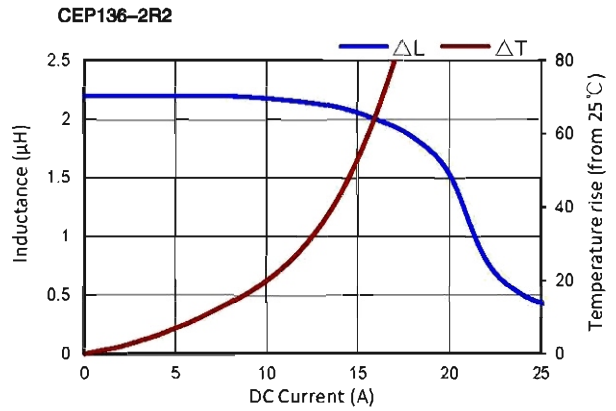
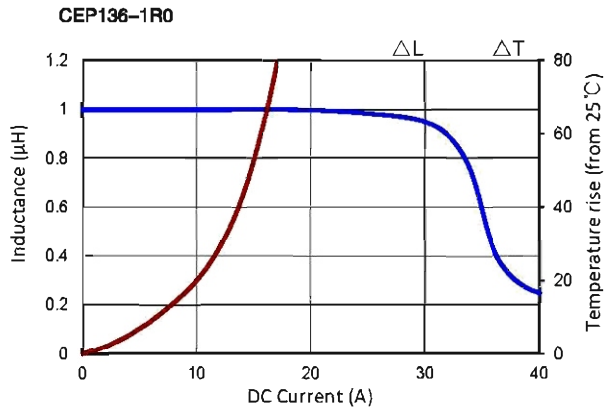

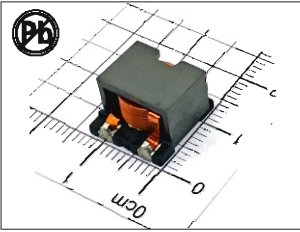

# HIGH CURRENT POWER INDUCTORS

## CEP 139 SERIES

### FEATURES:

- Compact size using flat wire, and SMD type
- Low radiation noise by magnetically shielded construction
- High current
- Low resistance

### COMMON APPLICATIONS:

- High efficiency DC/DC converters
- Single and polyphase buck converters
- Filter for audio applications
- Optimized for high current boost applications

### ELECTRICAL CHARACTERISTICS:

Part No.	Inductance @100KHz (uH) ± 20%	DCR (mΩ)	DC saturation current			Temperature rise 40°C current (A)Max
			L0 Drop 10% Max	L0 Drop 20% Max	L0 Drop 30% Max	
CEP139-100	10	15	11.4	12.6	13.2	9.2
CEP139-150	15	15	7.2	8.1	8.7	9.2
CEP139-220	22	23	6.1	6.8	7.4	7.7
CEP139-330	33	23	3.8	4.4	4.8	7.7
CEP139-470	47	23	2.6	3.0	3.2	7.7

### TECHNICAL INFORMATION & PHYSICAL CHARACTERISTICS:

#### Dimensions(mm)

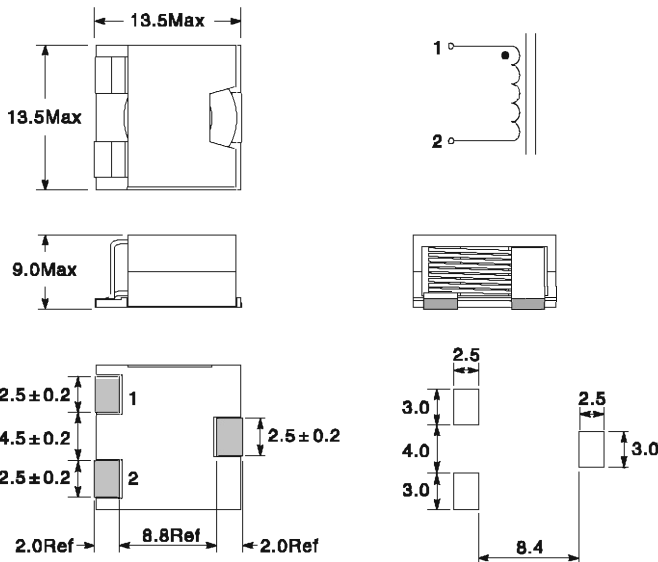

- Test Frequency : 100KHz / 0.25V
- Testing Instrument : L:HP4284A, CH11025, CH3302, CH1320, CH1320S LCR METER/Rdc:CH16502, Agilent33420A MICRO OHMMETER.
- The part temperature (ambient + temp rise) should not exceed 125°C under worst case operating conditions. Circuit design, component, PCB trace size and thickness, airflow and other cooling provisions all affect the part temperature. Part temperature should be verified in the end application.
- Operating Temperature & Storage Temperature: -40°C - +105°C.
- All specifications subject to change without notice.

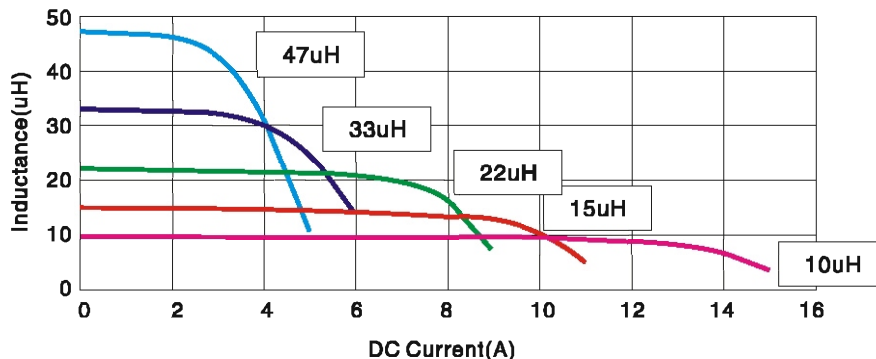

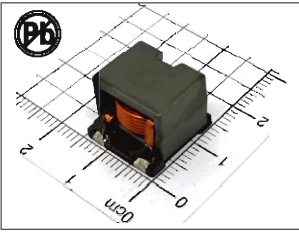

# HIGH CURRENT POWER INDUCTORS

## CEP 1412 SERIES

### FEATURES:

- Compact size using flat wire, and SMD type
- Low radiation noise by magnetically shielded construction
- High current
- Low resistance

### COMMON APPLICATIONS:

- High efficiency DC/DC converters
- Single and polyphase buck converters
- Filter for audio applications
- Optimized for high current boost applications

### ELECTRICAL CHARACTERISTICS:

Part No.	Inductance @ 100KHz (uH) ± 20%	DCR (mΩ)	DC saturation current			Temperature rise 40°C current (A)Max
			L0 Drop 10% Max	L0 Drop 20% Max	L0 Drop 30% Max	
CEP1412-100	10	7.98	11.9	13.1	13.5	10.1
CEP1412-120	12	9.42	10.7	11.8	12.5	9.7
CEP1412-150	15	10.8	9.8	10.9	11.6	9.1
CEP1412-180	18	12.6	9.1	10.0	10.5	8.4
CEP1412-220	22	15.2	7.9	8.8	9.4	7.8
CEP1412-330	33	17.9	7.0	7.9	8.6	7.1
CEP1412-470	47	17.9	6.0	6.9	7.4	6.5

### TECHNICAL INFORMATION & PHYSICAL CHARACTERISTICS:

#### Dimensions(mm)

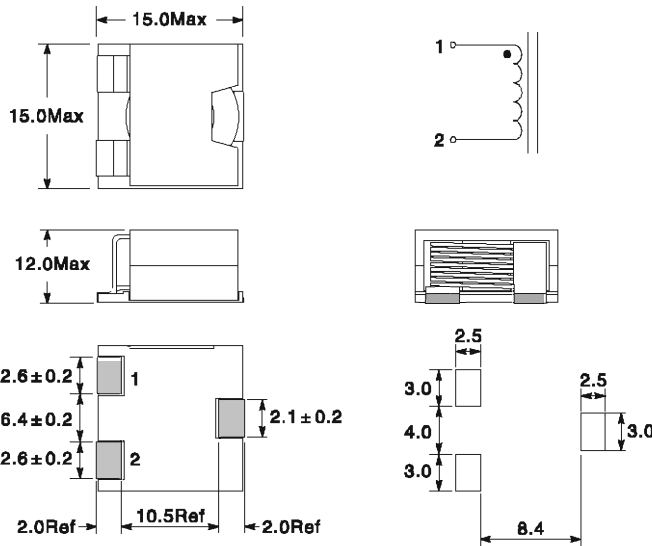

- Test Frequency : 100KHz / 0.25V
- Testing Instrument : L:HP4284A, CH11025, CH3302, CH1320, CH1320S LCR METER/Rdc:CH16502, Agilent33420A MICRO OHMMETER.
- The part temperature (ambient + temp rise) should not exceed 125°C under worst case operating conditions. Circuit design, component, PCB trace size and thickness, airflow and other cooling provisions all affect the part temperature. Part temperature should be verified in the end application.
- Operating Temperature & Storage Temperature: -40°C – +105°C.
- All specifications subject to change without notice.

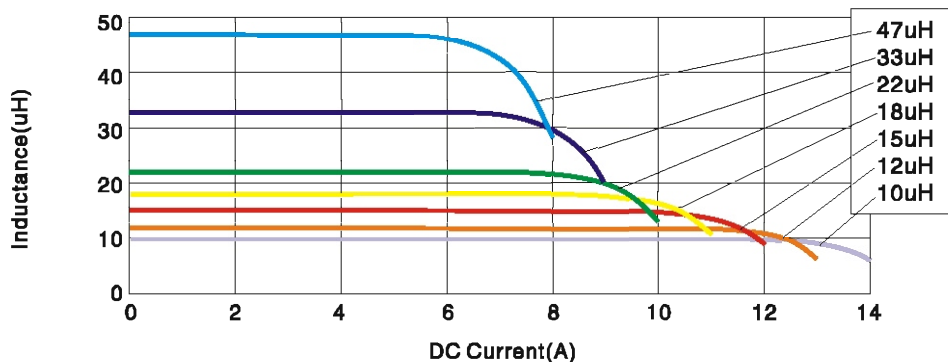

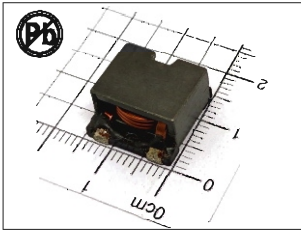

# HIGH CURRENT POWER INDUCTORS

## CEP 148 SERIES

### FEATURES:

- Compact size using flat wire, and SMD type
- Low radiation noise by magnetically shielded construction
- High current
- Low resistance

### COMMON APPLICATIONS:

- High efficiency DC/DC converters
- Single and polyphase buck converters
- Filter for audio applications
- Optimized for high current boost applications

### ELECTRICAL CHARACTERISTICS:

Part No.	Inductance @ 100KHz (uH) ± 20%	DCR (mΩ)	DC saturation current			Temperature rise 40°C current (A)Max
			L0 Drop 10% Max	L0 Drop 20% Max	L0 Drop 30% Max	
CEP148-0R5	0.5	1.2	39.0	42.0	43.0	23
CEP148-1R0	1.0	1.2	25.4	28.0	29.2	23
CEP148-2R2	2.2	2.0	19.0	21.0	21.8	20
CEP148-3R3	3.3	3.3	15.0	17.0	18.0	17.5
CEP148-4R7	4.7	5.0	12.0	14.0	15.0	16
CEP148-6R8	6.8	6.0	10.2	12.0	12.8	12.5
CEP148-8R2	8.2	7.8	9.0	10.0	10.7	11
CEP148-100	10.0	9.8	8.5	9.5	10.2	10
CEP148-120	12.0	13.0	7.5	8.5	9.2	8.5

### TECHNICAL INFORMATION & PHYSICAL CHARACTERISTICS:

#### Dimensions(mm)

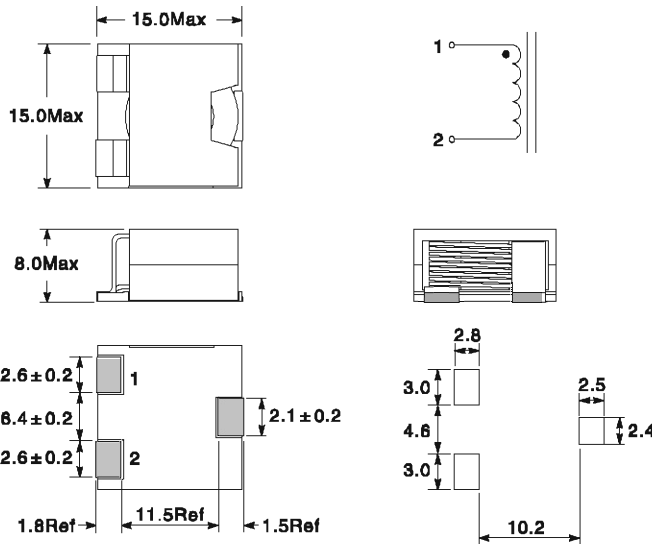

- Test Frequency : 100KHz / 0.25V
- Testing Instrument : L:HP4284A, CH11025, CH3302, CH1320, CH1320S LCR METER/Rdc:CH16502, Agilent33420A MICRO OHMMETER.
- The part temperature (ambient + temp rise) should not exceed 125°C under worst case operating conditions. Circuit design, component, PCB trace size and thickness, airflow and other cooling provisions all affect the part temperature. Part temperature should be verified in the end application.
- Operating Temperature & Storage Temperature: -40°C - +105°C.
- All specifications subject to change without notice.

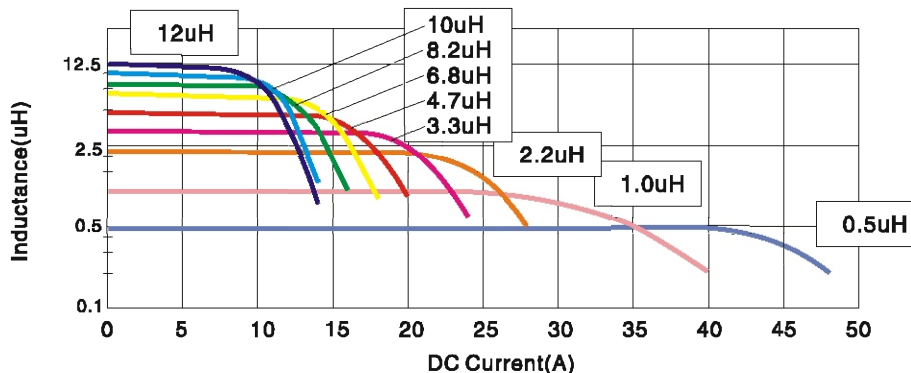

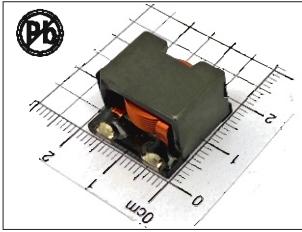

# HIGH CURRENT POWER INDUCTORS

## CEP 1812 SERIES

### FEATURES:

- Compact size using flat wire, and SMD type
- Low radiation noise by magnetically shielded construction
- High current
- Low resistance

### COMMON APPLICATIONS:

- High efficiency DC/DC converters
- Single and polyphase buck converters
- Filter for audio applications
- Optimized for high current boost applications

## ELECTRICAL CHARACTERISTICS:

Part No.	Inductance @ 100KHz (uH) ± 20%	DCR (mΩ)Max	DC saturation current L0 Drop 25% Max	Temperature rise 40°C current (A)Max
CEP1812-5R6	5.6	2.00	12.0	22.5
CEP1812-8R2	8.2	2.42	10.8	19.5
CEP1812-120	12	3.29	9.0	18.0
CEP1812-150	15	4.33	8.0	16.5
CEP1812-220	22	5.60	6.8	16.0
CEP1812-270	27	7.92	6.7	12.5
CEP1812-330	33	8.94	5.5	12.0

## TECHNICAL INFORMATION & PHYSICAL CHARACTERISTICS:

### Dimensions(mm)

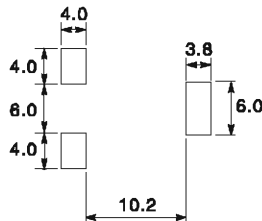
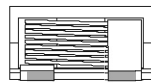
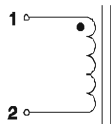
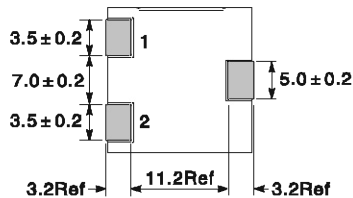
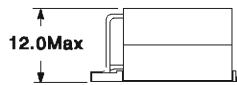
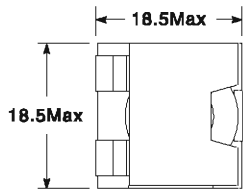

- Test Frequency : 100KHz / 0.25V
- Testing Instrument : L:HP4284A, CH11025, CH3302, CH1320, CH1320S LCR METER/Rdc:CH16502, Agilent33420A MICRO OHMMETER.
- The part temperature (ambient + temp rise) should not exceed 125°C under worst case operating conditions. Circuit design, component, PCB trace size and thickness, airflow and other cooling provisions all affect the part temperature. Part temperature should be verified in the end application.
- Operating Temperature & Storage Temperature: -40°C - +105°C.
- All specifications subject to change without notice.

# SMD HIGH CURRENT POWER INDUCTOR CEP2214 SERIES

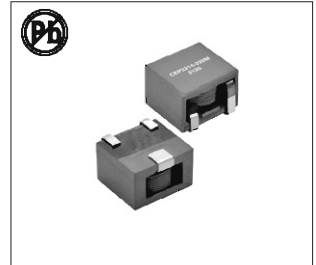

## FEATURES:

- Magnetic shielding structure, excellent resistance to electromagnetic interference
- Flat wire winding, low ESR, small parasitic capacitance
- Additional terminal design structure, soldering firmly
- Compact design saves Installation area
- Low power loss, suitable for applications of wide temperature and frequency range

## ELECTRICAL CHARACTERISTICS:@25°C

Part Number	Inductance (uH) ± 20%	DCR (mΩ) Max	Saturation current Isat(A)	Temperature rise current Irms(A)
CEP2214-3R3M	3.3	1.87	52	36.5
CEP2214-6R8M	6.8	1.87	27	36.5
CEP2214-120M	12.0	4.32	23.2	23.5
CEP2214-220M	22.0	4.32	12.5	23.5
CEP2214-330M	33.0	12.6	13.5	12.8
CEP2214-470M	47.0	12.6	10	12.8

## PHYSICAL CHARACTERISTICS: WINDING:

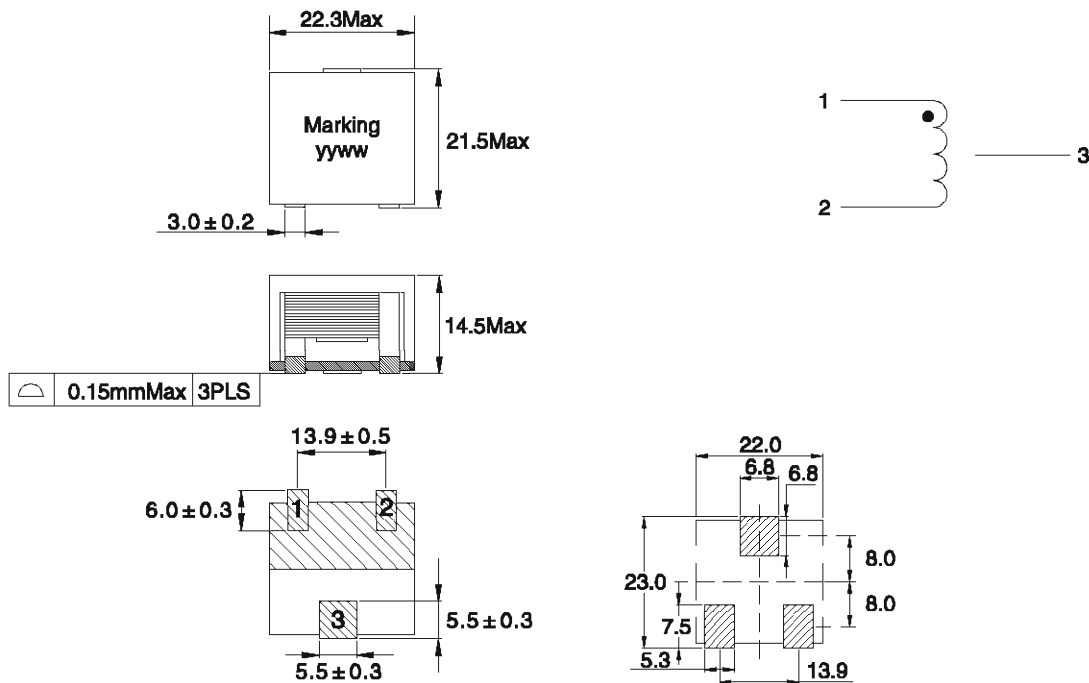

## GENERAL SPECIFICATIONS:

- All data is tested based on 25 °C ambient temperature
- Inductance measure condition at 100kHz, 1.0V.
- Saturation current: the actual value of DC current when the inductance decrease 20% of its initial value
- Temperature rise current: the actual value of DC current when the temperature rise is Δ T40 °C (Ta=25 °C )
- Special remind:Circuit design, component placement, PCB size and thickness, cooling system and etc. all will affect the product temperature. Please verify the product temperature in the final application
- Operating temperature : -40 °C to +125 °C (Including coil's temperature rise)

Note:All specifications subject to change without notice.

# SMD HIGH CURRENT POWER INDUCTOR CEP2214 SERIES

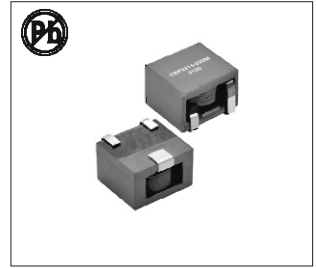

## SATURATION CURRENT VS TEMPERATURE RISE CURRENT CURVE

CEP2214-3R3M

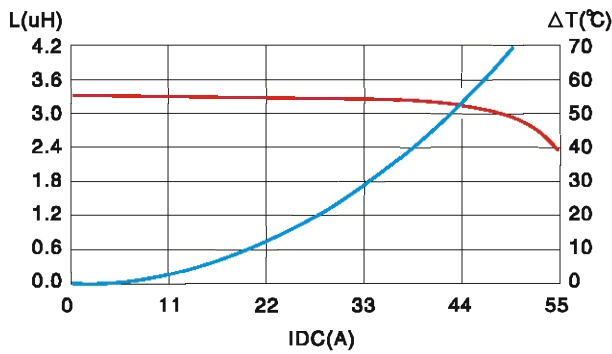

CEP2214-6R8M

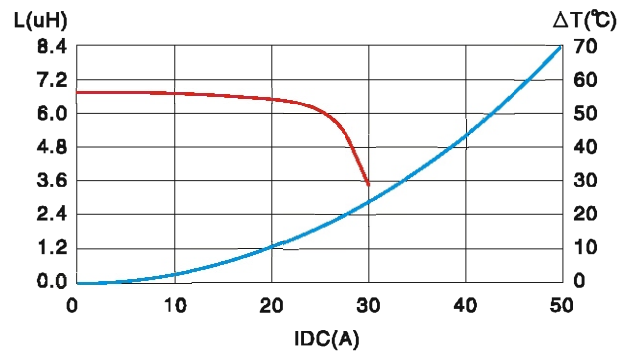

CEP2214-120M

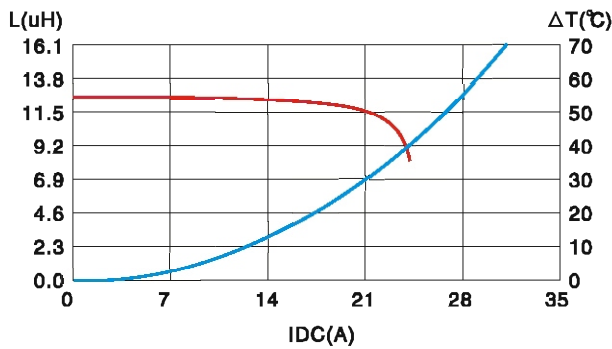

CEP2214-220M

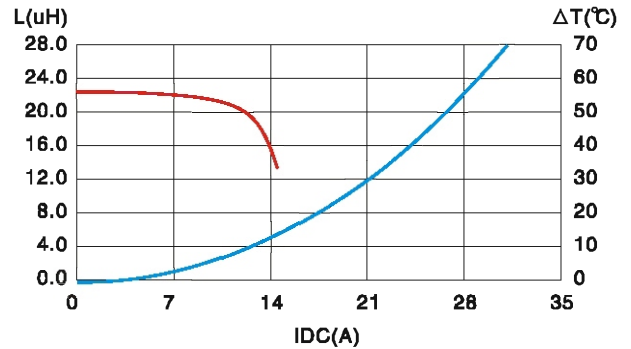

CEP2214-330M

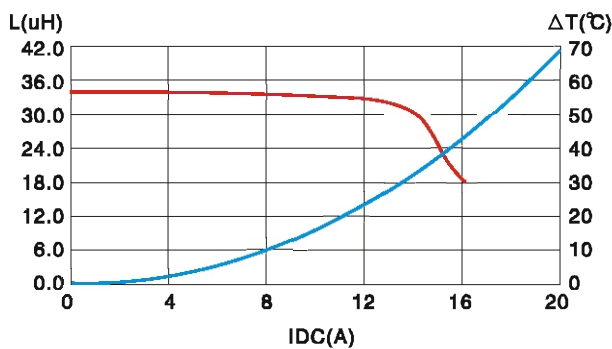

CEP2214-470M

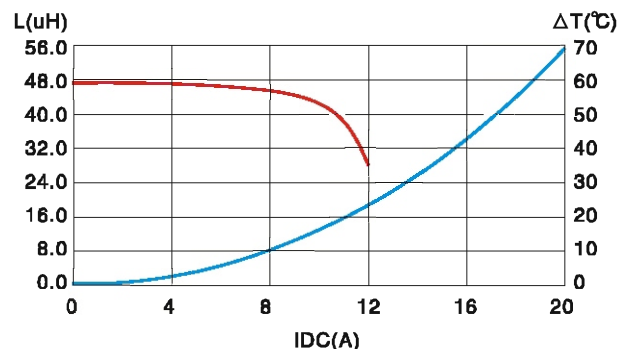

# SMD HIGH CURRENT POWER INDUCTOR CEP2214 SERIES

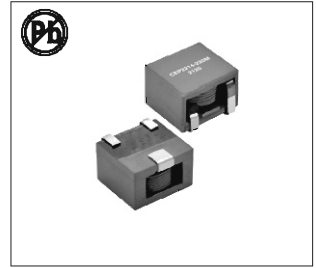

## IMPEDANCE VS FREQUENCY

CEP2214-3R3M

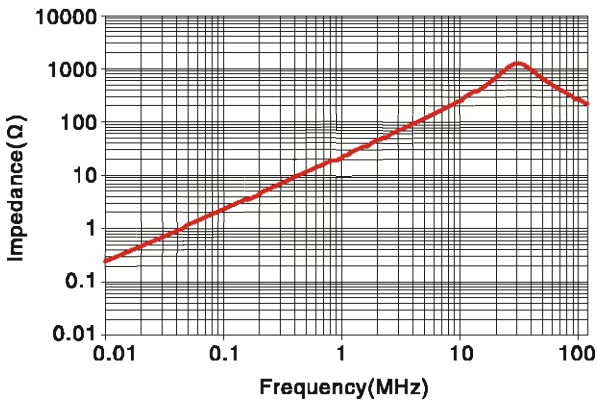

CEP2214-6R8M

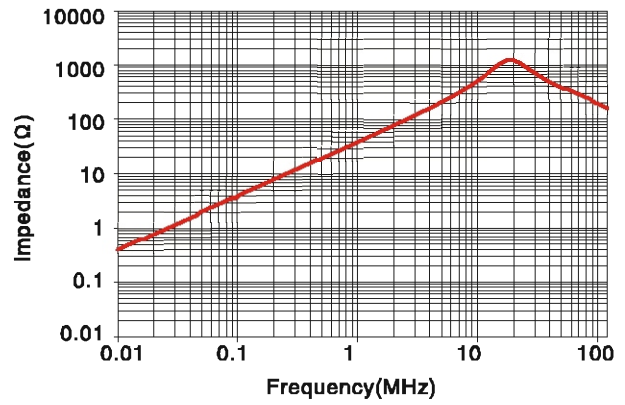

CEP2214-120M

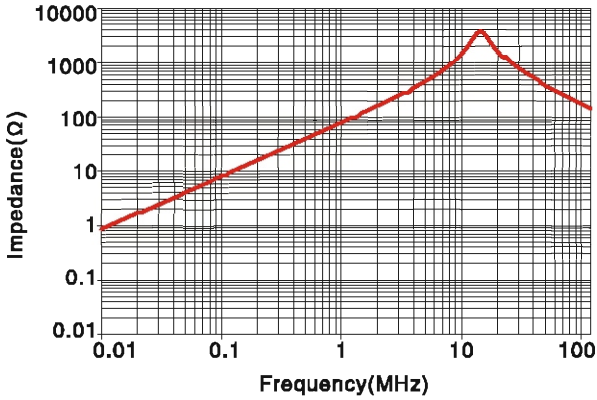

CEP2214-220M

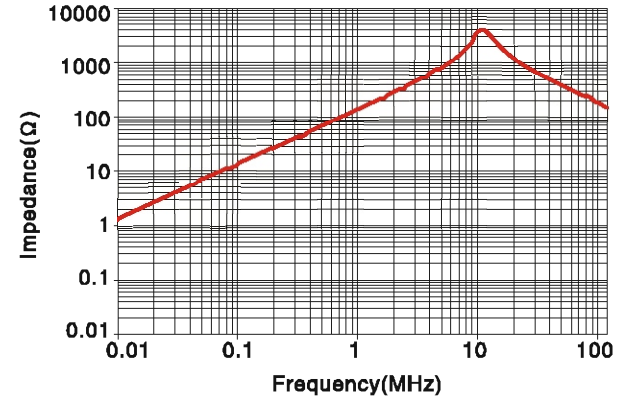

CEP2214-330M

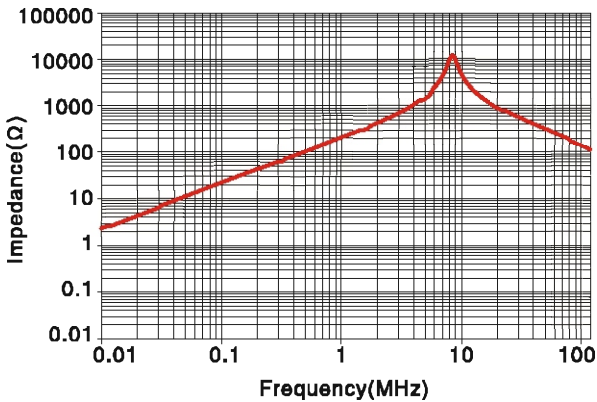

CEP2214-470M

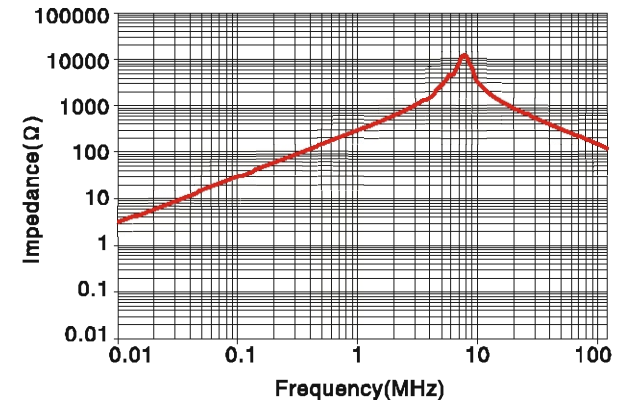

# HIGH CURRENT THROUGH-HOLE INDUCTOR

## DEP2520 SERIES



### APPLICATIONS:

- High current and high temperature applications
- DC/DC converters
- High current motor and switching noise suppression
- Inverters

### FEATURES:

- High temperature operation, up to 180°C continuous with no aging
- Low DCR to minimize losses and reduce temperature rise
- Powdered iron alloy core technology provides stable inductance and saturation over operating temperature with satisfactory core losses
- Soft saturation gives predictable inductance decrease with increasing DC current independent of temperature
- Standard terminal is stripped and tinned for through hole mounting but other terminal configurations such as bare copper, SMD, and press fit pin are available upon request
- Custom options are available

### ELECTRICAL CHARACTERISTICS@25°C

Part Number	Inductance (uH) ± 20% 100KHz,0.25V	DCR (mΩ)Max	SRF (MHz)Typ	Heat rating current I <sub>rms</sub> (A)	Saturation current I <sub>sat 1</sub> (A)	Saturation current I <sub>sat 2</sub> (A)
DEP2520-1R2M	1.2	0.30	90	80	110	150
DEP2520-2R2M	2.2	0.40	45	70	75	110
DEP2520-3R3M	3.3	0.70	25	50	60	90
DEP2520-4R7M	4.7	0.95	15	45	50	70
DEP2520-6R8M	6.8	1.15	10	40	45	60
DEP2520-8R2M	8.2	1.50	9	35	35	50
DEP2520-100M	10	2.00	8	30	30	45

### TECHNICAL INFORMATION & WINDING

Dimensions(mm)

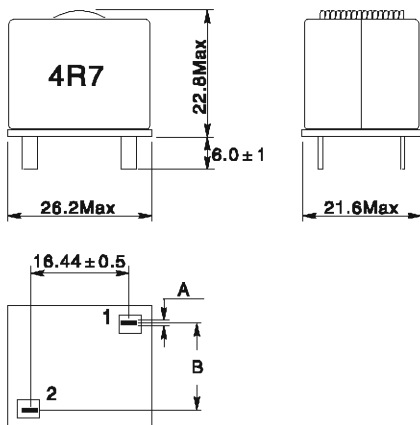

Part Number	A	B
DEP2520-1R2M	3.2	10.14
DEP2520-2R2M	2.5	10.84
DEP2520-3R3M	2.0	11.34
DEP2520-4R7M	1.8	11.54
DEP2520-6R8M	1.6	11.74
DEP2520-8R2M	1.4	11.94
DEP2520-100M	1.1	12.24

Winding

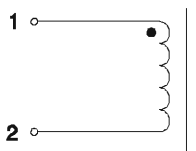

Note:

- All test data is referenced to 25°C ambient
- Operating temperature range -40°C to +180°C
- The part temperature (ambient + temp. rise) should not exceed 180°C under worst case operating conditions. Circuit design, component placement, PWB trace size and thickness, airflow and other cooling provisions all affect the part temperature. Part temperature should be verified in the end application
- Isolation voltage, coil to core: 350 VDC, 60s, 5 mA max.
- Heat Rated Current (I<sub>rms</sub>) will cause the coil temperature rise approximately, ΔT=40°C without core loss.
- Saturation Current (I<sub>sat 1</sub>) will cause L<sub>0</sub> to drop approximately 20%
- Saturation Current (I<sub>sat 2</sub>) will cause L<sub>0</sub> to drop approximately 30%

Note:All specifications subject to change without notice.

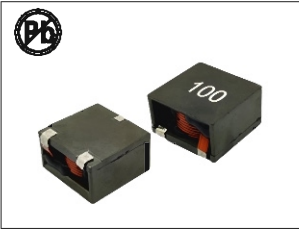

# HIGH CURRENT POWER INDUCTORS

## LPA2110 SERIES

### FEATURES:

- Compact size using flat wire, and SMD type
- Low radiation noise by magnetically shielded construction
- High current
- Low resistance

### COMMON APPLICATIONS:

- High efficiency DC/DC converters
- Single and polyphase buck converters
- Filter for audio applications
- Optimized for high current boost applications

### ELECTRICAL CHARACTERISTICS:

Part No.	Inductance @ 100KHz (uH) ± 20%	DCR (mΩ)Max	Temperature rise current Irms(A)Max	Saturation current @ 25°C Isat(A)Max	Height (mm)
LPA2110-1R0M	1	1.4	40	70	10.6
LPA2110-1R5M	1.5	1.4	40	52	10.6
LPA2110-2R2M	2.2	1.8	34	46	10.6
LPA2110-3R3M	3.3	2.2	28	37	10.6
LPA2110-4R7M	4.7	2.8	26	30	11.5

### TECHNICAL INFORMATION & PHYSICAL CHARACTERISTICS:

#### Dimensions(mm)

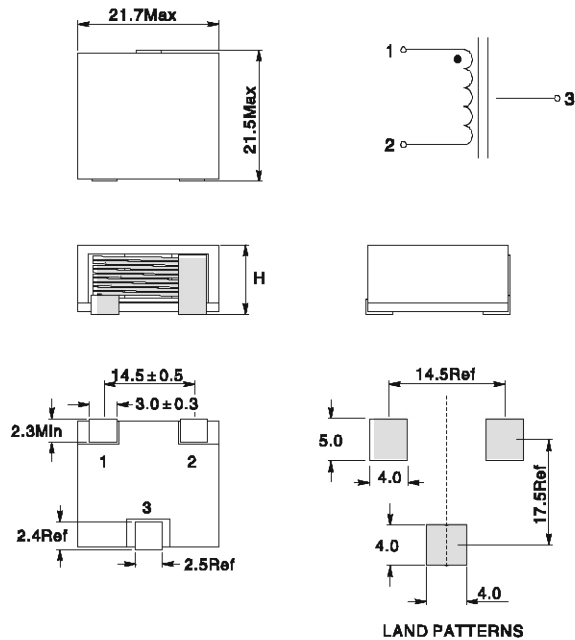

- Test Frequency : 100KHz / 0.25V
- Testing Instrument : L:HP4284A, CH11025,CH1320S LCR METER/Rdc:CH16502, Agilent33420A MICRO OHMMETER.
- Irms: DC current (A) that will cause an approximate ΔT of 40°C
- Isat: DC current (A) that will cause Lo to drop approximately 30%
- The part temperature (ambient + temp rise) should not exceed 125°C under worst case operating conditions. Circuit design, component, PCB trace size and thickness, airflow and other cooling provisions all affect the part temperature. Part temperature should be verified in the end application.
- Operating Temperature & Storage Temperature: -40°C – +125°C.
- All specifications subject to change without notice.



# HIGH CURRENT POWER INDUCTORS

## LPA2112 SERIES

### FEATURES:

- Compact size using flat wire, and SMD type
- Low radiation noise by magnetically shielded construction
- High current
- Low resistance

### COMMON APPLICATIONS:

- High efficiency DC/DC converters
- Single and polyphase buck converters
- Filter for audio applications
- Optimized for high current boost applications

### ELECTRICAL CHARACTERISTICS:

Part No.	Inductance @ 100KHz (uH) ± 20%	DCR (mΩ)Max	Temperature rise current Irms(A)Max	Saturation current @ 25°C Isat(A)Max	Height (mm)
LPA2112-6R8M	6.8	3.8	22	26	12.5
LPA2112-100M	10.5	6	17.5	22.5	12.5
LPA2112-150M	15.2	9.2	14	18.5	12.5
LPA2112-240M	24.5	15	11	14.5	12.5
LPA2112-320M	32.0	21.5	9	12.5	12.5
LPA2112-500M	50.0	32.6	7.4	10	12.5

### TECHNICAL INFORMATION & PHYSICAL CHARACTERISTICS:

#### Dimensions(mm)

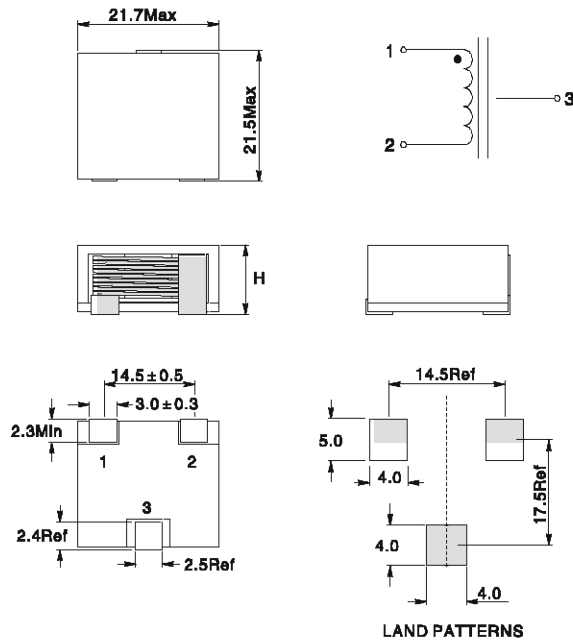

- Test Frequency : 100KHz / 0.25V
- Testing Instrument : L:HP4284A, CH11025,CH1320S LCR METER/Rdc:CH16502, Agilent33420A MICRO OHMMETER.
- Irms: DC current (A) that will cause an approximate ΔT of 40°C
- Isat: DC current (A) that will cause Lo to drop approximately 30%
- The part temperature (ambient + temp rise) should not exceed 125°C under worst case operating conditions. Circuit design, component, PCB trace size and thickness, airflow and other cooling provisions all affect the part temperature. Part temperature should be verified in the end application.
- Operating Temperature & Storage Temperature: -40°C – +125°C.
- All specifications subject to change without notice.

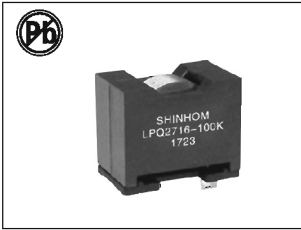

# HIGH CURRENT POWER INDUCTORS

## LPQ2716 SERIES

### FEATURES:

- Using flat wire
- Low radiation noise by magnetically shielded construction
- High current
- Low resistance

### COMMON APPLICATIONS:

- High efficiency DC/DC converters
- Single and polyphase buck converters
- Filter for audio applications
- Optimized for high current boost applications

### ELECTRICAL CHARACTERISTICS:

Part No.	Inductance @ 100KHz (uH) ± 20%	DCR (mΩ)Max	DC saturation current			Temperature rise 40°C current (A)Max
			L0 Drop 10% Max	L0 Drop 20% Max	L0 Drop 30% Max	
LPQ2716-3R3M	3.3	2.86	91	92.5	93.6	28
LPQ2716-4R7M	4.7	2.86	59	61.2	62.4	28
LPQ2716-6R8M	6.8	2.86	42	45	45.9	28
LPQ2716-100M	10	2.86	28	31.2	32.1	28
LPQ2716-150M	15	2.86	18	21.2	21.9	28
LPQ2716-220M	22	2.86	12	14.0	15.0	28
LPQ2716-330M	33	2.86	7	8.7	9.6	28

### TECHNICAL INFORMATION & PHYSICAL CHARACTERISTICS:

#### Dimensions(mm)

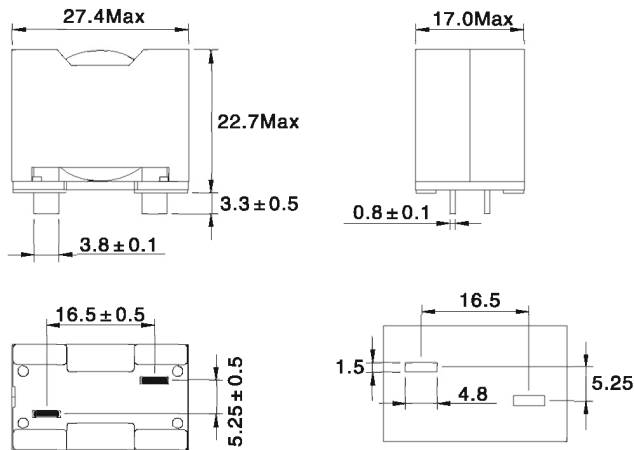

- Test Frequency : 100KHz / 0.25V
- Testing Instrument : L:HP4284A, CH11025, CH3302, CH1320, CH1320S LCR METER/Rdc:CH16502, Agilent33420A MICRO OHMMETER.
- The part temperature (ambient + temp rise) should not exceed 125°C under worst case operating conditions. Circuit design, component, PCB trace size and thickness, airflow and other cooling provisions all affect the part temperature. Part temperature should be verified in the end application.
- Operating Temperature & Storage Temperature: -40°C - +125°C.
- All specifications subject to change without notice.

#### Winding

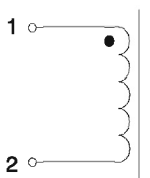

**ELECTRICAL CHARACTERISTIC CURVE:**

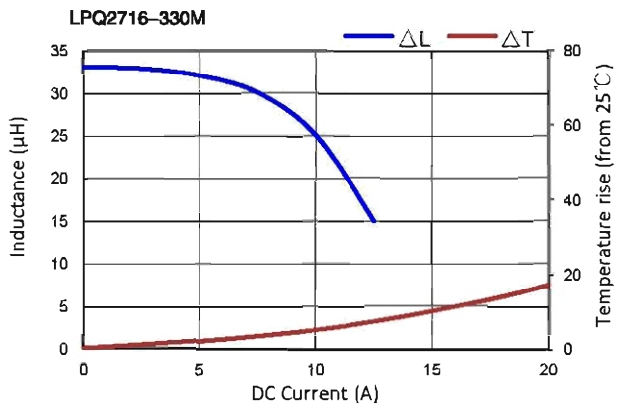
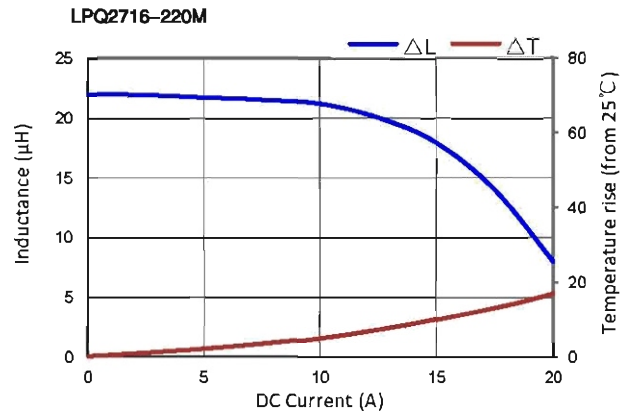
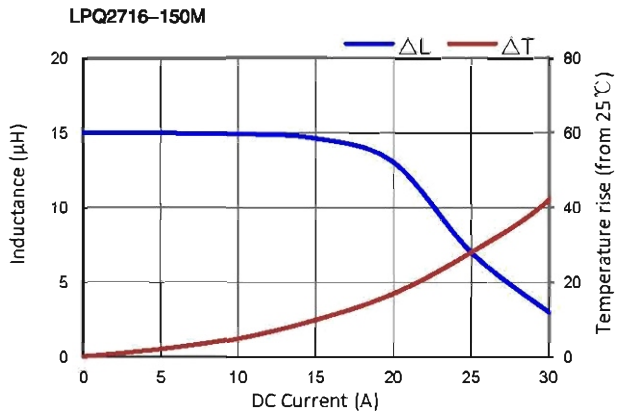
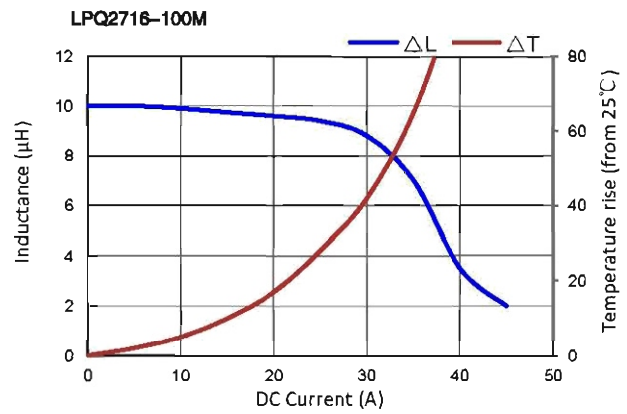
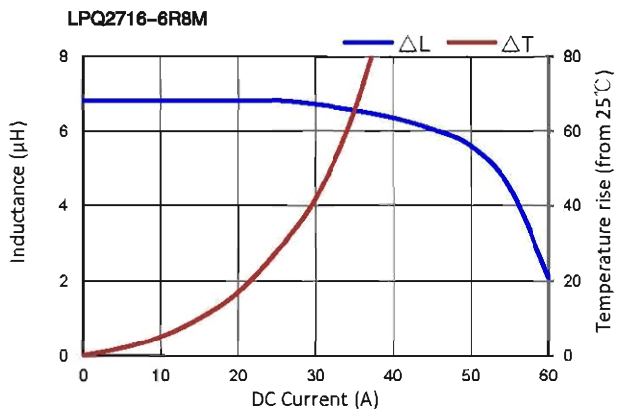
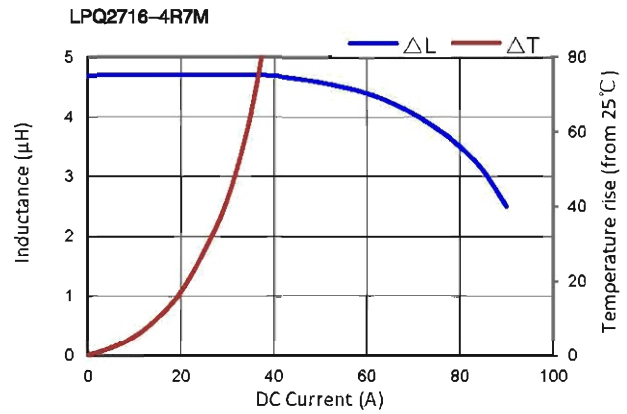
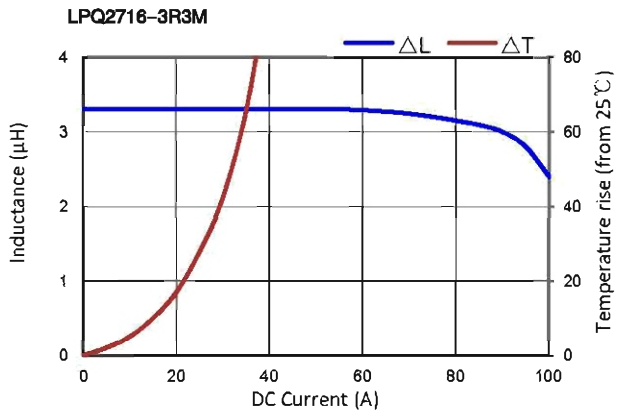



# HIGH CURRENT POWER INDUCTORS

## LPQ2716B SERIES

### FEATURES:

- Using flat wire
- Low radiation noise by magnetically shielded construction
- High current
- Low resistance

### COMMON APPLICATIONS:

- High efficiency DC/DC converters
- Single and polyphase buck converters
- Filter for audio applications
- Optimized for high current boost applications

### ELECTRICAL CHARACTERISTICS:

Part No.	Inductance @ 100KHz (uH) ± 20%	DCR (mΩ)Max	DC saturation current			Temperature rise 40°C current (A)Max
			L0 Drop 10% Max	L0 Drop 20% Max	L0 Drop 30% Max	
LPQ2716B-3R3M	3.3	2.86	91	92.5	93.6	28
LPQ2716B-4R7M	4.7	2.86	59	61.2	62.4	28
LPQ2716B-6R8M	6.8	2.86	42	45	45.9	28
LPQ2716B-100M	10	2.86	28	31.2	32.1	28
LPQ2716B-150M	15	2.86	18	21.2	21.9	28
LPQ2716B-220M	22	2.86	12	14.0	15.0	28
LPQ2716B-330M	33	2.86	7	8.7	9.6	28

### TECHNICAL INFORMATION & PHYSICAL CHARACTERISTICS:

#### Dimensions(mm)

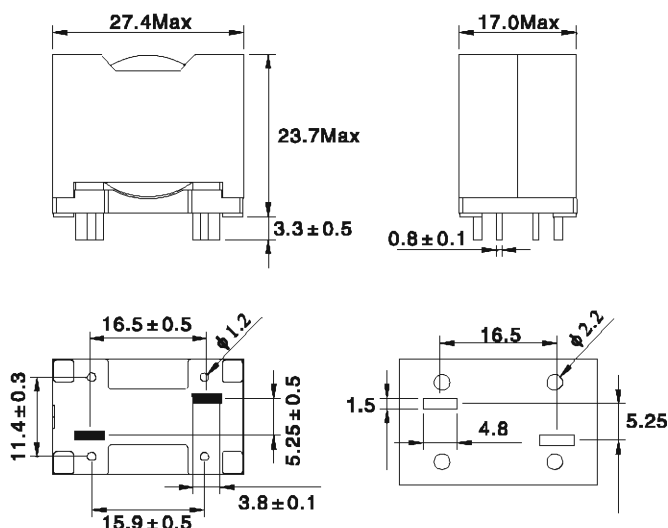

#### Winding

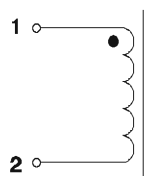

- Test Frequency : 100KHz / 0.25V
- Testing Instrument : L:HP4284A, CH11025, CH3302, CH1320, CH1320S LCR METER/Rdc:CH16502, Agilent33420A MICRO OHMMETER.
- The part temperature (ambient + temp rise) should not exceed 125°C under worst case operating conditions. Circuit design, component, PCB trace size and thickness, airflow and other cooling provisions all affect the part temperature. Part temperature should be verified in the end application.
- Operating Temperature & Storage Temperature: -40°C - +125°C.
- All specifications subject to change without notice.

**ELECTRICAL CHARACTERISTIC CURVE:**

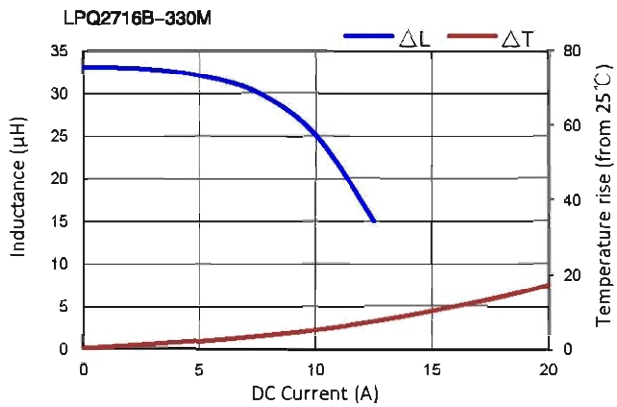
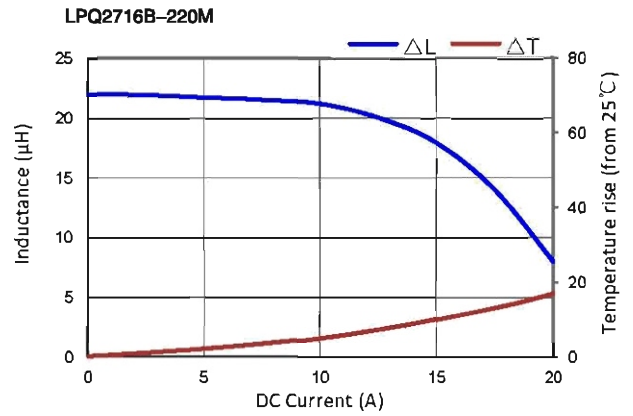
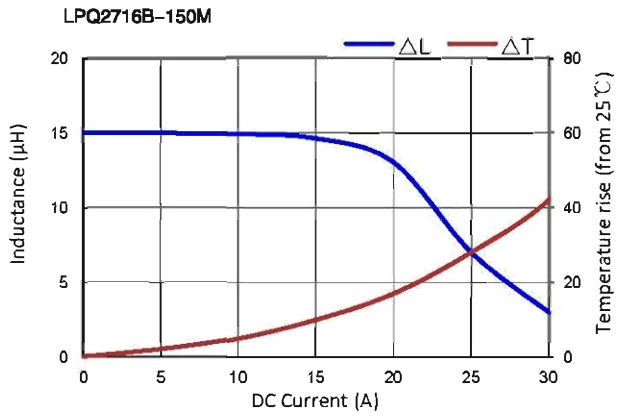
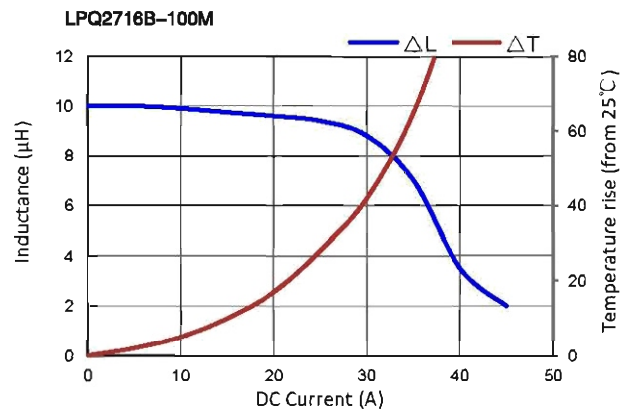
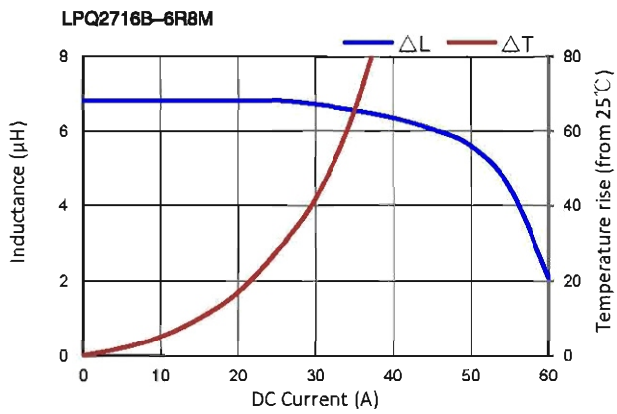
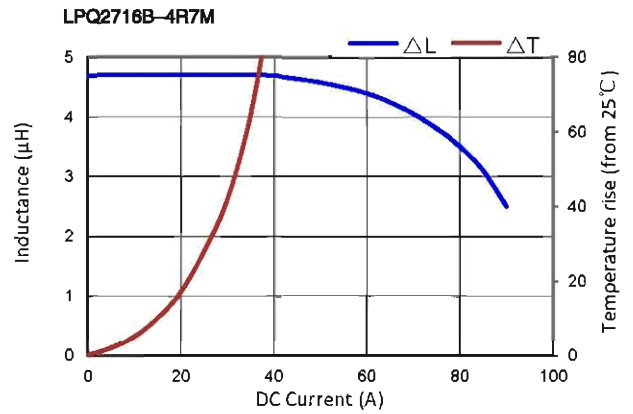
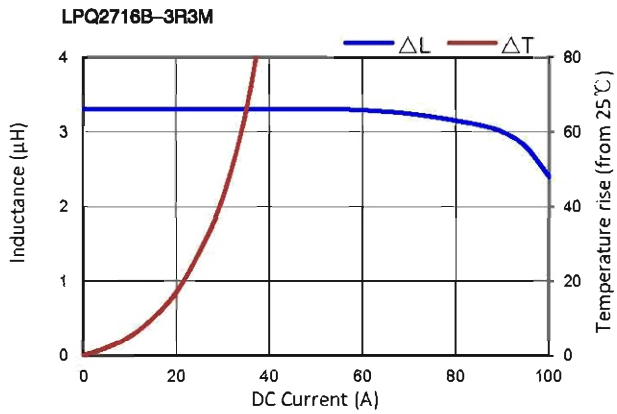

# HIGH CURRENT POWER INDUCTORS

## LPQ3218 SERIES



### FEATURES:

- Assemblage design, sturdy structure
- High inductance, high current, low magnetic loss, low ERS, small parasitic capacitance
- Flat wire winding, achieve a low DCR
- Temperature rise current and saturation current is less influenced by environment

### ELECTRICAL CHARACTERISTICS@25°C

Part Number	Inductance 100KHz, 0.1V ( $\mu$ H) $\pm$ 10%	DCR (m $\Omega$ ) Max	Isat (A) typ.	Irms (A) typ.
LPQ3218-3R3M	3.3	1.45	80	45
LPQ3218-4R7M	4.7	1.45	75	45
LPQ3218-5R0M	5.0	1.45	70	45
LPQ3218-6R0M	6.0	1.45	55	45
LPQ3218-6R8M	6.8	1.45	50	45

Note: 1. K=  $\pm$  10%, M=  $\pm$  20%, N=  $\pm$  30%

### PHYSICAL CHARACTERISTICS & WINDING

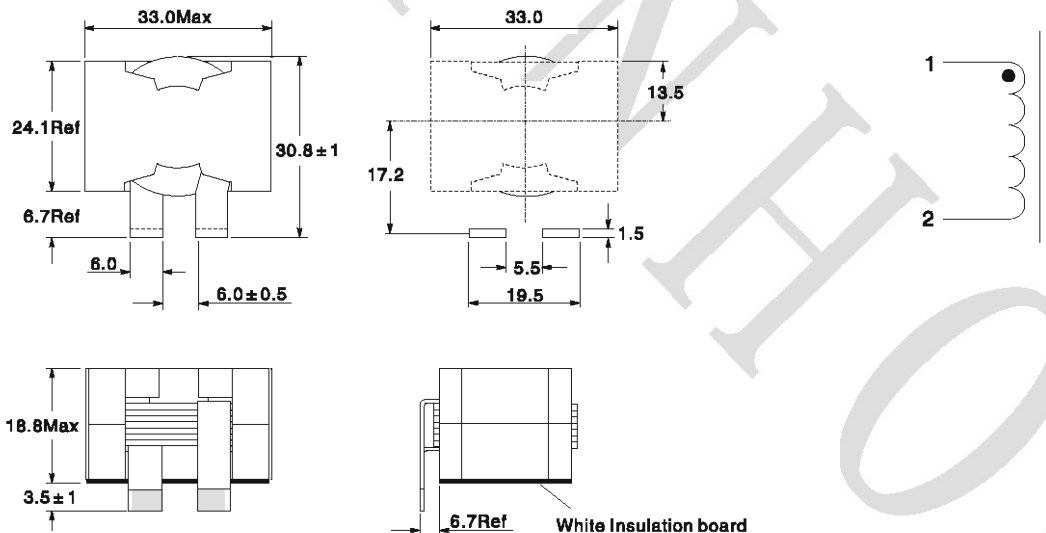

- All test data is referenced to 25°C ambient.
- Test condition: 100KHz, 0.1V
- I<sub>rms</sub>: DC current (A) that will cause an approximate  $\Delta T$  of 40°C.
- I<sub>sat</sub>: DC current (A) that will cause L<sub>o</sub> to drop approximate 30%.
- Operating temperature range is -25°C to 125°C.
- The part temperature (ambient and temp rise) should not exceed 125°C under worse case operating conditions. Circuit design, component placement, PWB trace size and thickness, airflow and other cooling provision all affect the part temperature. Part temperature should be verified in the end application.

# HIGH CURRENT POWER INDUCTORS SPQ2615A SERIES

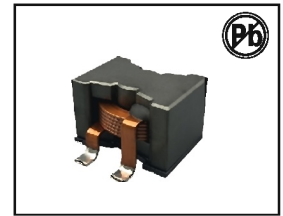

## FEATURES:

- High inductance, low magnetic loss, small parasitic capacitance
- Extremely low DCR; Current handling to >100 Amps
- Temperature rise current and saturation current is less influenced by environment
- Third mounting pad for greater stability and board adhesion

## ELECTRICAL CHARACTERISTICS@25°C

Part Number	Inductance 500KHz,0.1V (uH) ± 10%	DCR (mΩ)Max	SRF (MHz)typ	I <sub>rms</sub> (A)typ.		I <sub>sat</sub> (A)typ.		
				20°C rise	40°C rise	10% drop	20% drop	30% drop
SPQ2615A-2R2K	2.2	2.05	40	20	30	100	>100	>100
SPQ2615A-3R3K	3.3	2.05	30	20	30	62.0	66.9	68.4
SPQ2615A-4R7K	4.7	2.05	25	20	30	42.0	48.0	50.1
SPQ2615A-6R8K	6.8	2.05	20	20	30	30.0	34.5	36.2
SPQ2615A-100K	10	2.05	15	20	30	18.0	21.5	23.4
SPQ2615A-150K	15	2.05	12	20	30	11.5	14.0	15.2
SPQ2615A-220K	22	2.05	10	20	30	7.0	8.6	9.6
SPQ2615A-330K	33	2.05	8	20	30	4.0	5.1	5.9

## PHYSICAL CHARACTERISTICS & WINDING

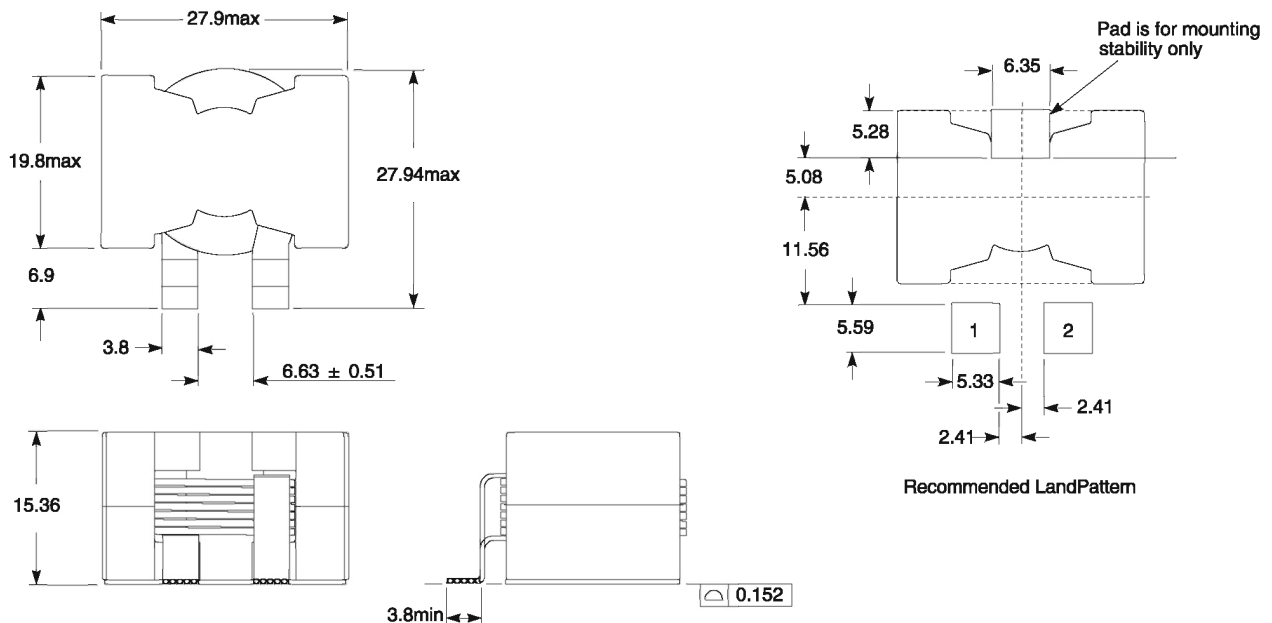

- All test data is referenced to 25°C ambient.
- Test condition: 500KHz,0.1V,0 Adc on an Agilent/HP 4284A LCR meter or equivalent.
- I<sub>rms</sub>:Current that causes the specified temperature rise from 25°C ambient. This information is for reference only and does not represent absolute maximum ratings. When I<sub>rms</sub> is greater than I<sub>sat</sub>, I<sub>sat</sub> is the more critical specification
- I<sub>sat</sub>:DC current at 25°C that causes the specified inductance drop from its value without current. When I<sub>sat</sub> rating is less than I<sub>rms</sub>, I<sub>sat</sub> is the more critical specification.
- Operating temperature range is -25°C to 125°C.
- Ambient temperature -40°C to +85°C with (40°C rise) I<sub>rms</sub> current.
- Maximum part temperature +125°C (ambient + temp rise)
- Storage temperature Component: -40°C to +125°C
- Resistance to soldering heat Max three 40 second reflows at +260°C, parts cooled to room temperature between cycles

# HIGH CURRENT POWER INDUCTORS

## TEMPERATURE RISE VS CURRENT

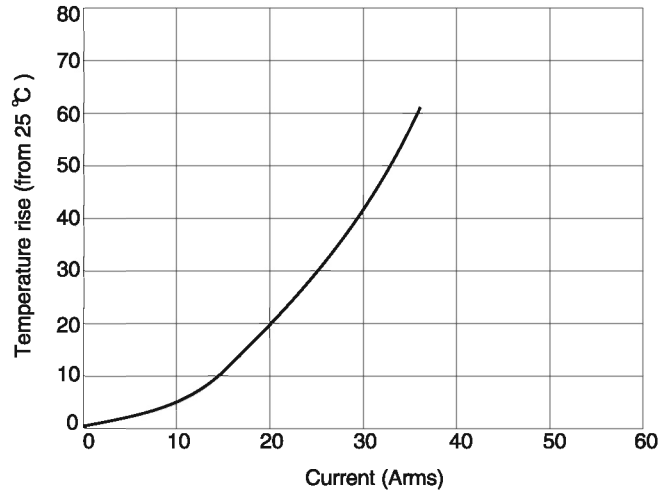

## L VS CURRENT      L VS FREQUENCY

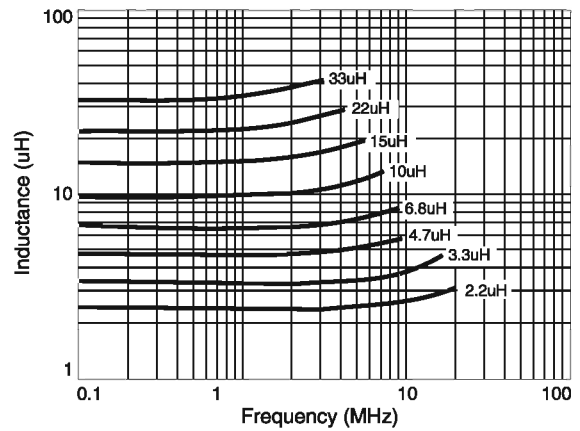
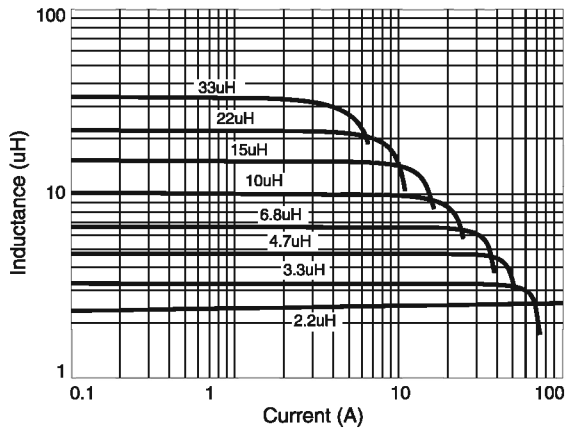

# HIGH CURRENT POWER INDUCTORS SPQ2615B SERIES

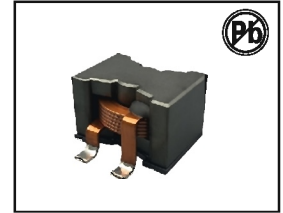

## FEATURES:

- High inductance, low magnetic loss, small parasitic capacitance
- Extremely low DCR; Current handling to >100 Amps
- Temperature rise current and saturation current is less influenced by environment
- Third mounting pad for greater stability and board adhesion

## ELECTRICAL CHARACTERISTICS@25°C

Part Number	Inductance 500KHz,0.1V (uH) ± 10%	DCR (mΩ)Max	SRF (MHz)typ	I <sub>rms</sub> (A)typ.		I <sub>sat</sub> (A)typ.		
				20°C rise	40°C rise	10% drop	20% drop	30% drop
SPQ2615B-1R5K	1.5	1.65	60	20	30	100	>100	>100
SPQ2615B-2R2K	2.2	1.65	50	20	30	82.0	84.0	84.8
SPQ2615B-3R3K	3.3	1.65	40	20	30	48.0	54.0	57.0
SPQ2615B-4R7K	4.7	1.65	30	20	30	33.0	36.9	39.0
SPQ2615B-6R8K	6.8	1.65	25	20	30	22.0	26.0	27.8
SPQ2615B-100K	10	1.65	20	20	30	13.0	16.2	17.6
SPQ2615B-150K	15	1.65	15	20	30	7.5	9.8	11.0
SPQ2615B-220K	22	1.65	10	20	30	4.5	6.0	6.8
SPQ2615B-330K	33	1.65	7	20	30	2.0	2.6	3.3

## PHYSICAL CHARACTERISTICS & WINDING

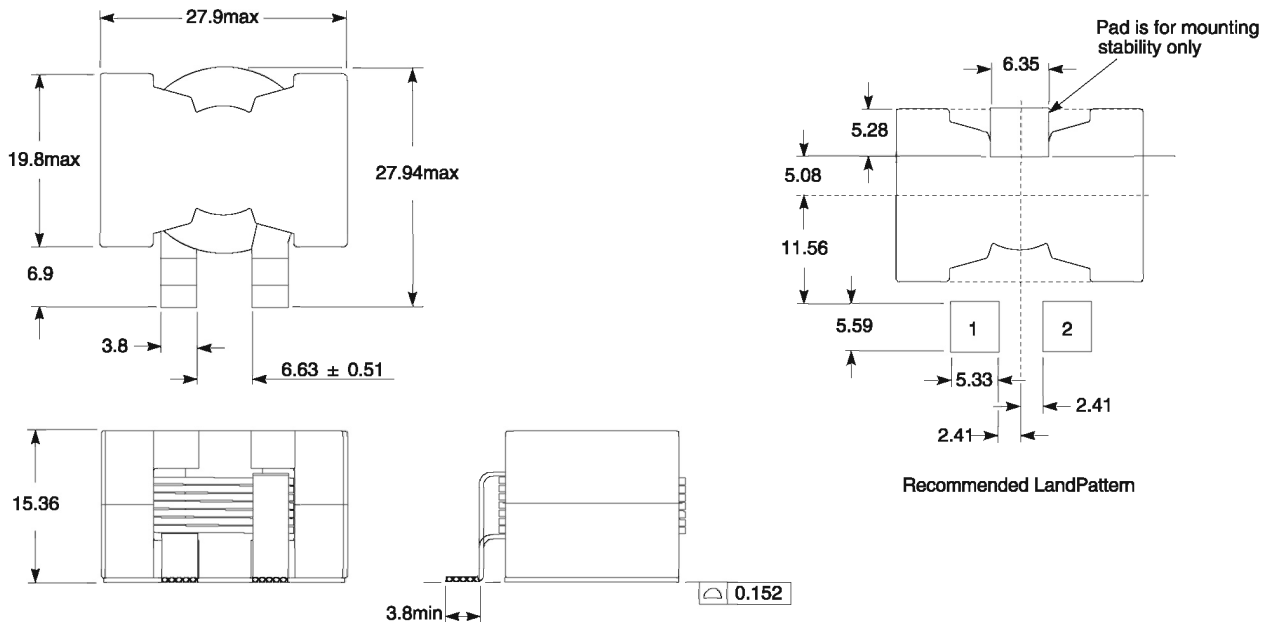

- All test data is referenced to 25°C ambient.
- Test condition: 500KHz,0.1V,0 Adc on an Agilent/HP 4284A LCR meter or equivalent.
- I<sub>rms</sub>:Current that causes the specified tempera-ture rise from 25°C ambient. This information is for reference only and does not represent absolute maximum ratings.When I<sub>rms</sub> is greater than I<sub>sat</sub>, I<sub>sat</sub> is the more critical specification
- I<sub>sat</sub>:DC current at 25°C that causes the specified inductance drop from its value without current. When I<sub>sat</sub> rating is less than I<sub>rms</sub>, I<sub>sat</sub> is the more critical specification.
- Operating temperature range is -25°C to 125°C.
- Ambient temperature -40°C to +85°C with (40°C rise) I<sub>rms</sub> current.
- Maximum part temperature +125°C (ambient + temp rise)
- Storage temperature Component: -40°C to +125°C
- Resistance to soldering heat Max three 40 second reflows at +260°C, parts cooled to room temperature between cycles

# HIGH CURRENT POWER INDUCTORS

## TEMPERATURE RISE VS CURRENT

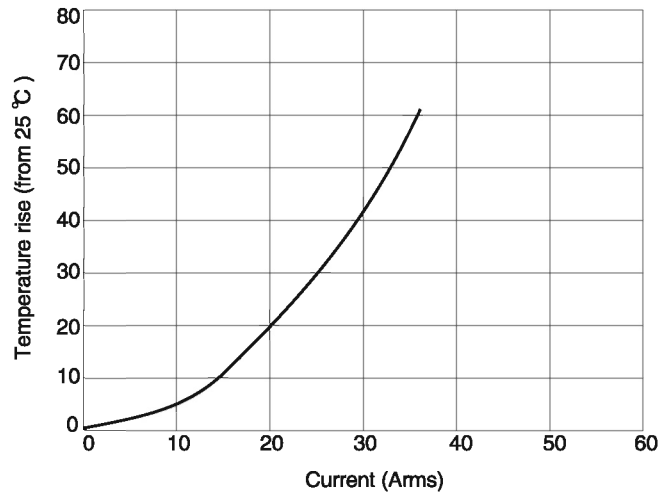

## L VS CURRENT      L VS FREQUENCY

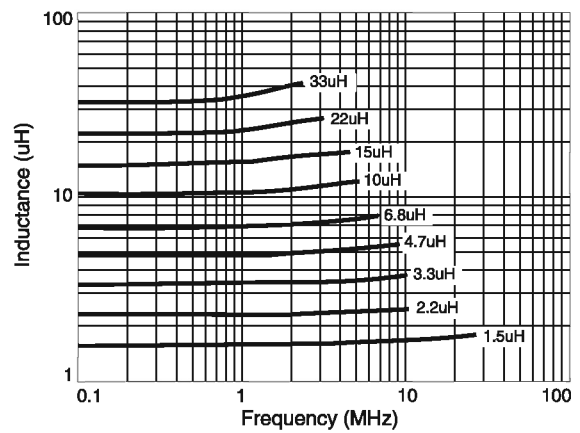
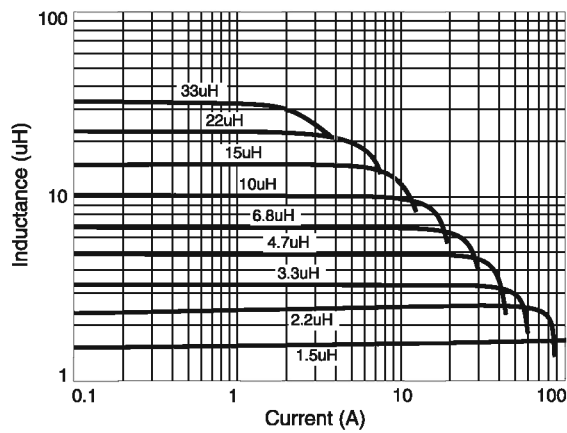

# HIGH CURRENT POWER INDUCTORS SPQ2618A SERIES

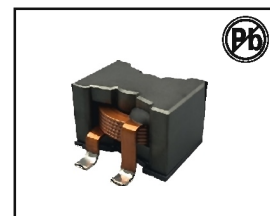

## FEATURES:

- High inductance, low magnetic loss, small parasitic capacitance
- Extremely low DCR; Current handling to 93 Amps
- Temperature rise current and saturation current is less influenced by environment
- Third mounting pad for greater stability and board adhesion

## ELECTRICAL CHARACTERISTICS@25°C

Part Number	Inductance 500KHz,0.1V (uH) ± 10%	DCR (mΩ)Max	SRF (MHz)typ	I <sub>rms</sub> (A)typ.		I <sub>sat</sub> (A)typ.		
				20°C rise	40°C rise	10% drop	20% drop	30% drop
SPQ2618A-3R3K	3.3	2.86	40	20	28	91.0	92.5	93.6
SPQ2618A-4R7K	4.7	2.86	30	20	28	59.0	61.2	62.4
SPQ2618A-6R8K	6.8	2.86	25	20	28	42.0	45.0	45.9
SPQ2618A-100K	10	2.86	20	20	28	28.0	31.2	32.1
SPQ2618A-150K	15	2.86	16	20	28	18.0	21.2	21.9
SPQ2618A-220K	22	2.86	15	20	28	12.0	14.0	15.0
SPQ2618A-330K	33	2.86	10	20	28	7.0	8.7	9.6

## PHYSICAL CHARACTERISTICS & WINDING

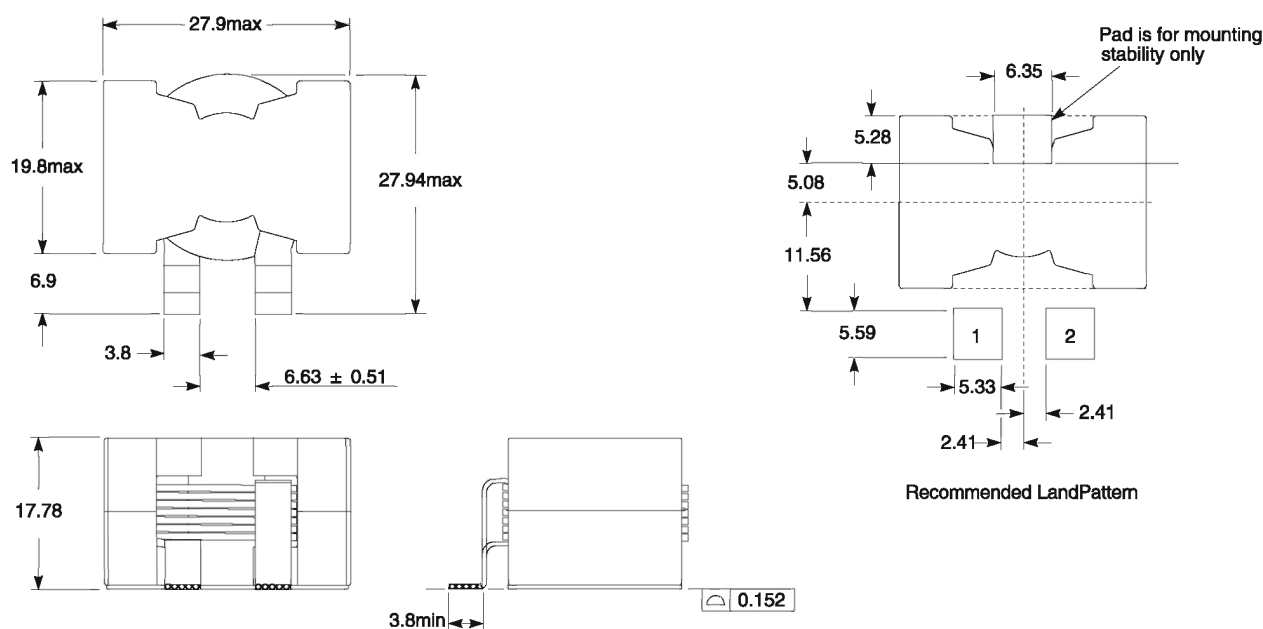

- All test data is referenced to 25°C ambient.
- Test condition: 500KHz,0.1V,0 Adc on an Agilent/HP 4284A LCR meter or equivalent.
- I<sub>rms</sub>: Current that causes the specified temperature rise from 25°C ambient. This information is for reference only and does not represent absolute maximum ratings. When I<sub>rms</sub> is greater than I<sub>sat</sub>, I<sub>sat</sub> is the more critical specification
- I<sub>sat</sub>: DC current at 25°C that causes the specified inductance drop from its value without current. When I<sub>sat</sub> rating is less than I<sub>rms</sub>, I<sub>sat</sub> is the more critical specification.
- Operating temperature range is -25°C to 125°C.
- Ambient temperature -40°C to +85°C with (40°C rise) I<sub>rms</sub> current.
- Maximum part temperature +125°C (ambient + temp rise)
- Storage temperature Component: -40°C to +125°C
- Resistance to soldering heat Max three 40 second reflows at +260°C, parts cooled to room temperature between cycles

# HIGH CURRENT POWER INDUCTORS

## TEMPERATURE RISE VS CURRENT

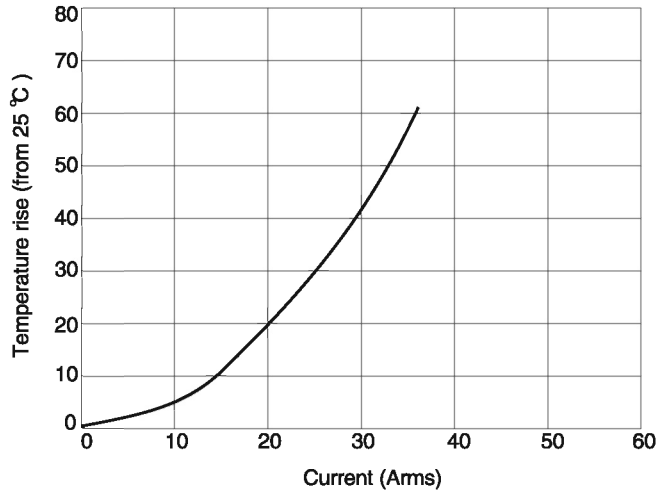

## L VS CURRENT      L VS FREQUENCY

